

SİLİKON CEPHE
SILICONE FACADE

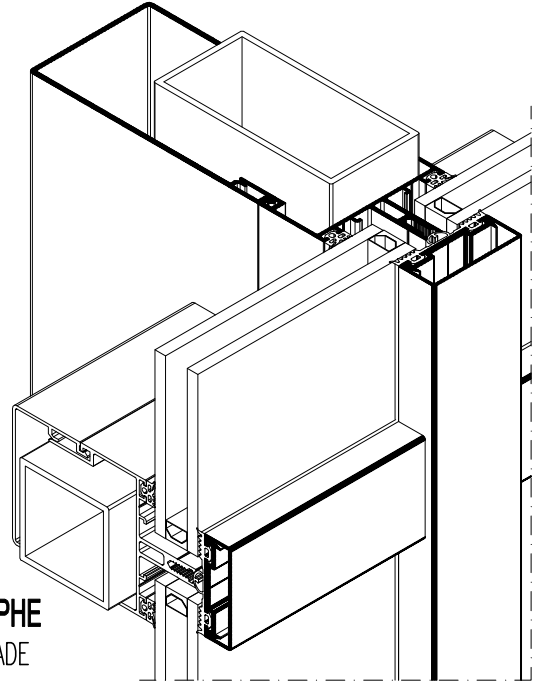

KAPAKLI CEPHE
COVER FACADE

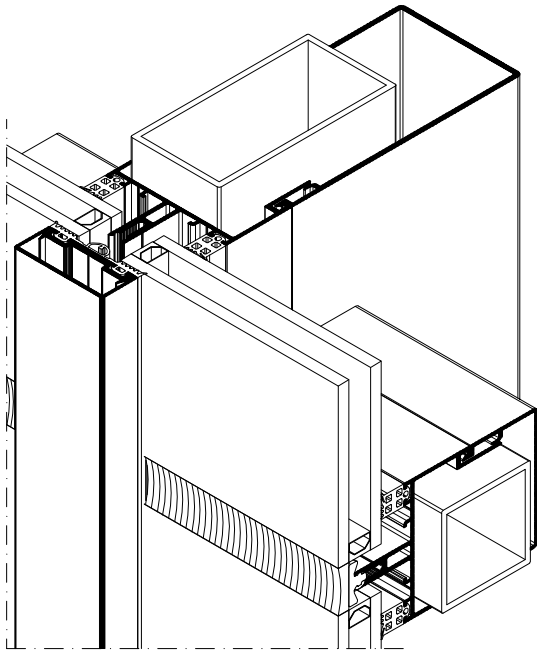







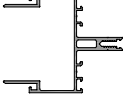

YARI KAPAKLI CEPHE
SEMI COVERED FACADE

ÇT68
ÇELİK TAKVİYELİ CEPHE
STEEL REINFORCED FACADE

ÇT68
ÇELİK TAKVİYELİ CEPHE
STEEL REINFORCED FACADE

ÜRÜN TEKNİK ÖZELLİKLERİ
PRODUCT'S TECHNICAL FEATURES

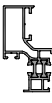
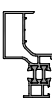





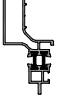

No. Nr.	PROFİL KESİTİ PROFILE VIEW	PROFİL NO PROFILE NO	PROFİL AÇIKLAMASI PROFILE DESCRIPTION	BAĞLANTI PARÇALARI CORNER CLEATS	gr/m	STATİK STATIC			
						Ix cm ⁴	Iy cm ⁴	Wx cm ³	Wy cm ³
1		ÇT68-101 (82,8 - 68) (1,6 mm)	TAŞIYICI PROFİL MULLION OR TRANSOM PROFILE		1411				
2		ÇT68-301 (65 - 9)	BASKI PROFİLİ PRESSURE PROFILE	ÇT68-302	489				
3		ÇT68-302 (20 - 68) (1,4 mm)	KAPAK PROFİLİ COVER PROFILE	ÇT68-301	402				
4		ÇT68-303 (42,2 - 68) (1,6 mm)	KAPAK PROFİLİ COVER PROFILE		750				
5		ÇT68-304 (133,7 - 68) (2,2 mm)	KAPAK PROFİLİ COVER PROFILE		2020				
6		SC0201 (34,9 - 49,5) (1,3 mm)	ÇİFT CAM PANEL PROFİLİ PANEL PROFILE FOR DOUBLE GLASS	SC0308-a (25,68 mm) SC0307-a (10,25 mm) SC0304-a (50 mm)	734				
7		SC0202 (34,9 - 49,5) (1,3 mm)	TEK CAM PANEL PROFİLİ PANEL PROFILE FOR SINGLE GLASS	SC0308-a (25,68 mm) SC0307-a (10,25 mm) SC0304-a (50 mm)	636				
8		SC0203 (34,9 - 57) (1,3 mm)	KOMPOZİT PANEL PROFİLİ PANEL PROFILE FOR COMPOSITE	SC0308-a (25,68 mm) SC0307-a (10,25 mm) SC0304-a (50 mm)	643				
9		SC0204 (34,9 - 59,6) (1,3 mm)	ÇİFT CAM PANEL PROFİLİ PANEL PROFILE FOR DOUBLE GLASS	SC0308-b (29,74 mm) SC0309-a (6,5 mm) SC0304-a (50 mm)	PVC 970 POLYAMİD 963				
10		SC0205 (34,9 - 59,6) (1,3 mm)	TEK CAM PANEL PROFİLİ PANEL PROFILE FOR SINGLE GLASS	SC0308-b (29,74 mm) SC0309-a (6,5 mm) SC0304-a (50 mm)	PVC 894 POLYAMİD 886				

Profil değerleri teoriktir. Ağırlık olarak testimde yapılan tartım geçerlidir.
Profil imalatları TS EN 12020-2 ve TS EN 755-9 toleransları,
Moment değerleri EN 14024'e göre hesaplanmıştır.

Profile values are theoretical pre-shipment weight will be valid.
The tolerances of Profile manufacturing are calculated according to EN 12020-2
and TS EN 755-9; moment values are calculated according to EN 14024.

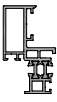
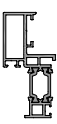
ÇT68
ÇELİK TAKVİYELİ CEPHE
STEEL REINFORCED FACADE

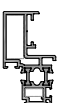
ÜRÜN TEKNİK ÖZELLİKLERİ
PRODUCT'S TECHNICAL FEATURES



No. Nr.	PROFİL KESİTİ PROFILE VIEW	PROFİL NO PROFILE NO	PROFİL AÇIKLAMASI PROFILE DESCRIPTION	BAĞLANTI PARÇALARI CORNER CLEATS	gr/m	STATİK STATIC			
						Ix cm ⁴	Iy cm ⁴	Wx cm ³	Wy cm ³
11		SC0206 (34.9 - 59.1) (13 mm)	KOMPOZİT PANEL PROFİLİ PANEL PROFILE FOR COMPOSITE	SC0308-b (29,74 mm) SC0309-a (6,5 mm) SC0304-a (50 mm)	PVC 924 POLYAMİD 916				
12		SC0207 (19.1 - 4.9) (15 mm)	SİLİKON YAPIŞTIRMA PR. SILICONE BONDING PROFILE		109				
13		SC0209 (22.1 - 49.5) (13 mm)	BITİM PROFİLİ COMPLETION PROFILE	SC0307-a (10,25 mm) SC0304-a (50 mm)	593				
14		SC0210 (36.1 - 50.5) (2 mm)	ÇİFT CAM PANEL PROFİLİ PANEL PROFILE FOR DOUBLE GLASS	SC0308-a (25,68 mm) SC0307-a (10,25 mm) SC0304-a (50 mm)	1001				
15		SC0214 (36.1 - 61.1) (2 mm)	ÇİFT CAM PANEL PROFİLİ PANEL PROFILE FOR DOUBLE GLASS	SC0308-b (29,74 mm) SC0309-a (6,5 mm) SC0304-a (50 mm)	PVC 1275 POLYAMİD 1268				
16		SC0215 (33.2 - 73.1) (2 mm)	ÇİFT CAM PANEL PROFİLİ PANEL PROFILE FOR DOUBLE GLASS	SC0308-b (29,74 mm) SC0309-a (6,5 mm) SC0304-a (50 mm)	PVC 1365 POLYAMİD 1350				
17		SC0216 (32 - 71.6) (13 mm)	TEK CAM PANEL PROFİLİ PANEL PROFILE FOR SINGLE GLASS	SC0308-b (29,74 mm) SC0309-a (6,5 mm) SC0304-a (50 mm)	PVC 1060 POLYAMİD 1045				
18		SC0218 (33.5 - 64.5) (13 mm)	ÇİFT CAM PANEL PROFİLİ PANEL PROFILE FOR DOUBLE GLASS	SC0308-b (29,74 mm) SC0308-g (19,5 mm) SC0304-a (50 mm)	1250				
19		SC0219 (33.5 - 64.5) (2 mm)	ÇİFT CAM PANEL PROFİLİ PANEL PROFILE FOR DOUBLE GLASS	SC0308-b (29,74 mm) SC0308-l (5,6 mm) SC0304-a (50 mm)	PVC 1449 POLYAMİD 1442				
20		SC0304 (19 - 7.6) (2.8 mm)	DIŞTAN BAĞLANTI PROFİLİ OUTSIDE CONNECTION PROFILE		238				

Profil değerleri teoriktir. Ağırlık olarak testimde yapılan tartım geçerlidir.
Profil imalatları TS EN 12020-2 ve TS EN 755-9 toleransları,
Moment değerleri EN 14024'e göre hesaplanmıştır.

Profile values are theoretical pre-shipment weight will be valid.
The tolerances of Profile manufacturing are calculated according to EN 12020-2
and TS EN 755-9; moment values are calculated according to EN 14024.

ÇT68
ÇELİK TAKVİYELİ CEPHE
STEEL REINFORCED FACADE

ÜRÜN TEKNİK ÖZELLİKLERİ
PRODUCT'S TECHNICAL FEATURES





No. Nr.	PROFİL KESİTİ PROFILE VIEW	PROFİL NO PROFILE NO	PROFİL AÇIKLAMASI PROFILE DESCRIPTION	BAĞLANTI PARÇALARI CORNER CLEATS	gr/m	STATİK STATIC			
						Ix cm ⁴	Iy cm ⁴	Wx cm ³	Wy cm ³
21		SC0307 (55 - 55) (9.71 mm)	KÖŞE BİRLEŞTİRME PROFİLİ CORNER CLEATS PROFILE		2140				
22		SC0308 (70 - 70) (11.82 mm)	KÖŞE BİRLEŞTİRME PROFİLİ CORNER CLEATS PROFILE		2392				
23		SC0309 (55 - 55) (6.9 mm)	KÖŞE BİRLEŞTİRME PROFİLİ CORNER CLEATS PROFILE		1636				
24		SC0312 (25.1 - 4.2) (2 mm)	CAM OTURTMA PROFİLİ GLAZING SUPPORT FOR SASH PROFILE		147				
25		SC0343 (12.1 - 21.7) (1.8 mm)	İÇTEN BAĞLANTI PROFİLİ INSIDE CONNECTION PROFILE		173				
26		SC0344 (16 - 25.4) (2 mm)	İÇTEN BAĞLANTI PROFİLİ INSIDE CONNECTION PROFILE		244				
27		SC0350 (23.2 - 6.7) (12 mm)	CAM OTURTMA PROFİLİ GLAZING SUPPORT FOR SASH PROFILE		140				
28		MC0201 (20 - 35.5) (2 mm)	TIRNAK ADAPTÖR PROFİLİ CLAW ADAPTER PROFILE		397				
29		MC0202 (18 - 31.5) (2 mm)	TIRNAK ADAPTÖR PROFİLİ CLAW ADAPTER PROFILE		378				
30		KC0201 (54.6 - 59) (13 mm)	SAKLI KANAT KASA PR. OUTER FRAME PROFILE	SC0307-b (27 mm) SC0309-b (8.55 mm)	737				

Profil değerleri teoriktir. Ağırlık olarak testimde yapılan tartım geçerlidir.
Profil imalatları TS EN 12020-2 ve TS EN 755-9 toleransı,
Moment değerleri EN 14024'e göre hesaplanmıştır.

Profile values are theoretical pre-shipment weight will be valid.
The tolerances of Profile manufacturing are calculated according to EN 12020-2
and TS EN 755-9; moment values are calculated according to EN 14024.

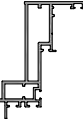
ÇT68
ÇELİK TAKVİYELİ CEPHE
STEEL REINFORCED FACADE

ÜRÜN TEKNİK ÖZELLİKLERİ
PRODUCT'S TECHNICAL FEATURES

No. Nr.	PROFİL KESİTİ PROFILE VIEW	PROFİL NO PROFILE NO	PROFİL AÇIKLAMASI PROFILE DESCRIPTION	BAĞLANTI PARÇALARI CORNER CLEATS	gr/m	STATİK STATIC			
						Ix cm ⁴	Iy cm ⁴	Wx cm ³	Wy cm ³
31		KC0202 (53.2 - 70.6) (13 mm)	SAKLI KANAT KASA PR. OUTER FRAME PROFILE	SC0309-c (18.9 mm)	792				
32		KC0203 (46.9 - 53.9) (13 mm)	SAKLI KANAT KASA PR. OUTER FRAME PROFILE	SC0309-c (18.9 mm)	662				
33		KC0204 (59.5 - 81.3) (20 mm)	SAKLI KANAT KASA PR. OUTER FRAME PROFILE	SC0308-h (9.9 mm) SC0309-j (52.8 mm)	1463				
34		KC0301 (46.9 - 9) (2 mm)	BASKI PROFİLİ PRESSURE PROFILE		496				
35		KC0302 (46.8 - 10.3) (2.4 mm)	BASKI PROFİLİ PRESSURE PROFILE		395				
36		KC0306 (20 - 50) (15 mm)	KAPAK PROFİLİ COVER PROFILE	KC0301 VEYA OR KC0302	343				
37		KC0309 (12 - 50) (15 mm)	KAPAK PROFİLİ COVER PROFILE	KC0301 VEYA OR KC0302	283				
38		KC0310 (15 - 50) (15 mm)	KAPAK PROFİLİ COVER PROFILE	KC0301 VEYA OR KC0302	308				
39		KC0311 (25 - 50) (15 mm)	KAPAK PROFİLİ COVER PROFILE	KC0301 VEYA OR KC0302	403				
40		KC0312 (30 - 50) (15 mm)	KAPAK PROFİLİ COVER PROFILE	KC0301 VEYA OR KC0302	455				

Profil değerleri teoriktir. Ağırlık olarak testimde yapılan tartım geçerlidir.
Profil imalatları TS EN 12020-2 ve TS EN 755-9 toleransı,
Moment değerleri EN 14024'e göre hesaplanmıştır.

Profile values are theoretical pre-shipment weight will be valid.
The tolerances of Profile manufacturing are calculated according to EN 12020-2
and TS EN 755-9; moment values are calculated according to EN 14024.

ÇT68
ÇELİK TAKVİYELİ CEPHE
STEEL REINFORCED FACADE

ÜRÜN TEKNİK ÖZELLİKLERİ
PRODUCT'S TECHNICAL FEATURES

No. Nr.	PROFİL KESİTİ PROFILE VIEW	PROFİL NO PROFILE NO	PROFİL AÇIKLAMASI PROFILE DESCRIPTION	BAĞLANTI PARÇALARI CORNER CLEATS	gr/m	STATİK STATIC			
						Ix cm ⁴	Iy cm ⁴	Wx cm ³	Wy cm ³
41		KC0313 (50 - 50) (15 mm)	KAPAK PROFİLİ COVER PROFILE	KC0301 VEYA OR KC0302	745				
42		KC0314 (75 - 50) (13 mm)	KAPAK PROFİLİ COVER PROFILE	KC0301 VEYA OR KC0302	954				
43		KC0315 (30 - 50) (13 mm)	KAPAK PROFİLİ COVER PROFILE	KC0301 VEYA OR KC0302	397				
44		KC0316 (50 - 50) (13 mm)	KAPAK PROFİLİ COVER PROFILE	KC0301 VEYA OR KC0302	611				
45		KC0317 (100 - 50) (13 mm)	KAPAK PROFİLİ COVER PROFILE	KC0301 VEYA OR KC0302	1214				
46		KC0320 (75 - 50) (13 mm)	KAPAK PROFİLİ COVER PROFILE	KC0301 VEYA OR KC0302	879				
47		KC0322 (18,5 - 50) (13 mm)	KAPAK PROFİLİ COVER PROFILE	KC0301 VEYA OR KC0302	262				
48		KC0323 (6 - 42) (15 mm)	KAPAK PROFİLİ COVER PROFILE	KC0325	261				
49		KC0324 (5,5 - 32) (15 mm)	KAPAK PROFİLİ COVER PROFILE	KC0325	186				
50		KC0326 (75 - 50) (13 mm)	KAPAK PROFİLİ COVER PROFILE	KC0323 VEYA OR KC0324	753				

Profil değerleri teoriktir. Ağırlık olarak testimde yapılan tartım geçerlidir.
Profil imalatları TS EN 12020-2 ve TS EN 755-9 toleransı,
Moment değerleri EN 14024'e göre hesaplanmıştır.

Profile values are theoretical pre-shipment weight will be valid.
The tolerances of Profile manufacturing are calculated according to EN 12020-2
and TS EN 755-9; moment values are calculated according to EN 14024.

ÇT68
ÇELİK TAKVİYELİ CEPHE
STEEL REINFORCED FACADE

ÜRÜN TEKNİK ÖZELLİKLERİ
PRODUCT'S TECHNICAL FEATURES



No. Nr.	PROFİL KESİTİ PROFILE VIEW	PROFİL NO PROFILE NO	PROFİL AÇIKLAMASI PROFILE DESCRIPTION	BAĞLANTI PARÇALARI CORNER CLEATS	gr/m	STATİK STATIC			
						Ix cm ⁴	Iy cm ⁴	Wx cm ³	Wy cm ³
51		SC0303 (4,4 - 19,5) (15 mm)	T1J PROFİLİ PUSHING ROD PROFILE		96				
52		KC0331 (20 - 11) (12 mm)	TEK CAM ADAPTÖRÜ PR. SINGLE GLAZING ADAPTER PROFILE		209				
53		KC0332 (22 - 11) (12 mm)	TEK CAM ADAPTÖRÜ PR. SINGLE GLAZING ADAPTER PROFILE		222				
54		KC0333 (16 - 11) (12 mm)	TEK CAM ADAPTÖRÜ PR. SINGLE GLAZING ADAPTER PROFILE		183				
55		KC0334 (18 - 11) (12 mm)	TEK CAM ADAPTÖRÜ PR. SINGLE GLAZING ADAPTER PROFILE		196				
56		KC0336 (33,2 - 9,4) (2 mm)	TEK CAM ADAPTÖRÜ PR. SINGLE GLAZING ADAPTER PROFILE		305				
57		KC0346 (36 - 9,3) (13 mm)	KAPAK PROFİLİ COVER PROFILE	KC0325	183				
58		KC0350 (6 - 11) (1 mm)	TEK CAM ADAPTÖRÜ PR. SINGLE GLAZING ADAPTER PROFILE		96				
59		KC0351 (14 - 11) (12 mm)	TEK CAM ADAPTÖRÜ PR. SINGLE GLAZING ADAPTER PROFILE		154				
60	  İşaretili profil için satış ekibinden bilgi alınız.	KC0352 (30 - 1) (12 mm)	TEK CAM ADAPTÖRÜ PR. SINGLE GLAZING ADAPTER PROFILE		274				

Profil değerleri teoriktir. Ağırlık olarak testimde yapılan tartım geçerlidir.
Profil imalatları TS EN 12020-2 ve TS EN 755-9 toleransı,
Moment değerleri EN 14024'e göre hesaplanmıştır.

Profile values are theoretical pre-shipment weight will be valid.
The tolerances of Profile manufacturing are calculated according to EN 12020-2
and TS EN 755-9; moment values are calculated according to EN 14024.

ÇT68
ÇELİK TAKVİYELİ CEPHE
STEEL REINFORCED FACADE

ÜRÜN TEKNİK ÖZELLİKLERİ
PRODUCT'S TECHNICAL FEATURES

No. Nr.	PROFİL KESİTİ PROFILE VIEW	PROFİL NO PROFILE NO	PROFİL AÇIKLAMASI PROFILE DESCRIPTION	BAĞLANTI PARÇALARI CORNER CLEATS	gr/m	STATİK STATIC			
						Ix cm ⁴	Iy cm ⁴	Wx cm ³	Wy cm ³
61		KC0347 (24 - 11) (12 mm)	TEK CAM ADAPTÖRÜ PR. SINGLE GLAZING ADAPTER PROFILE		235				
62	1	KC0325 (3.4 - 13.2) (1 mm)	KAPAK PROFİLİ COVER PROFILE	KC0323 VEYA OR KC0324	43				
63		SC0217 (13.8 - 27.9) (13 mm)	BİTİM PROFİLİ COMPLETION PROFILE	SC0304-a (50 mm)	242				
64									
65									
66									
67									
68									
69									
70									

Profil değerleri teoriktir. Ağırlık olarak testimde yapılan tartım geçerlidir.
Profil imalatları TS EN 12020-2 ve TS EN 755-9 toleransı,
Moment değerleri EN 14024'e göre hesaplanmıştır.

Profile values are theoretical pre-shipment weight will be valid.
The tolerances of Profile manufacturing are calculated according to EN 12020-2
and TS EN 755-9; moment values are calculated according to EN 14024.

ÇT68
ÇELİK TAKVİYELİ CEPHE
STEEL REINFORCED FACADE

ÜRÜN TEKNİK ÖZELLİKLERİ
PRODUCT'S TECHNICAL FEATURES

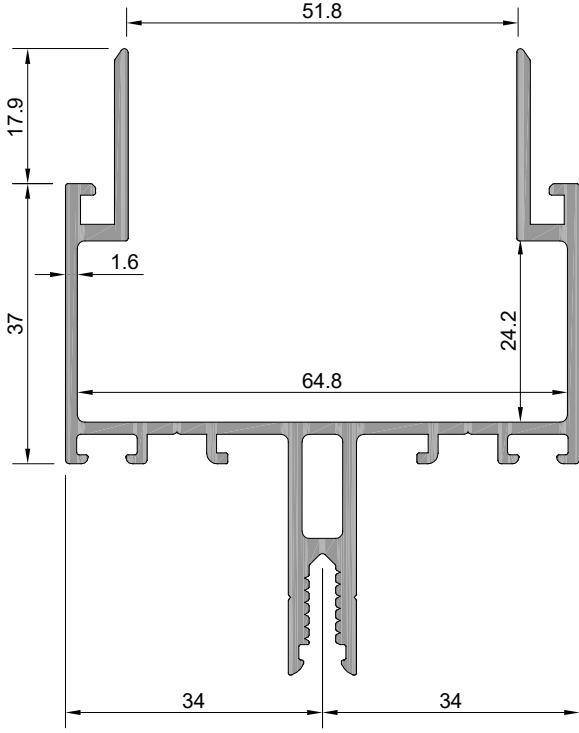

Profil No: ÇT68-101
Ağırlık : 1411 gr/m

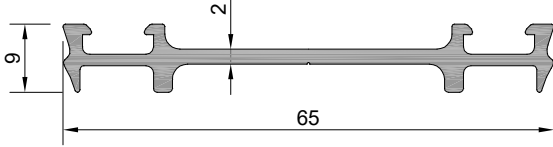

Profil No: ÇT68-301
Ağırlık : 489 gr/m

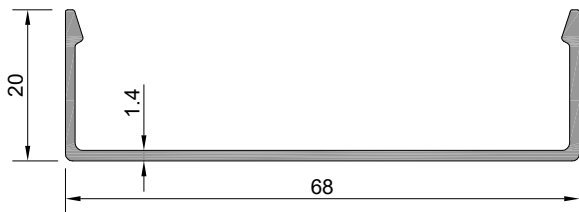

Profil No: ÇT68-302
Ağırlık : 402 gr/m

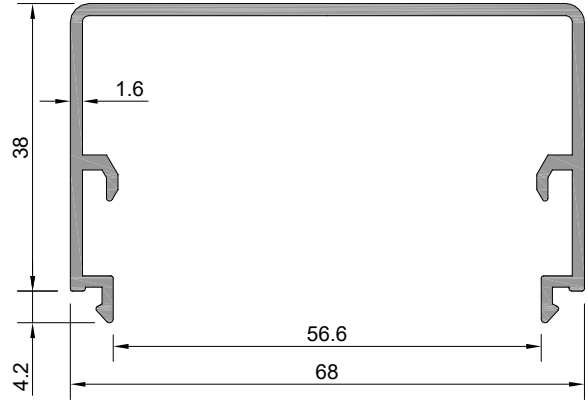

Profil No: ÇT68-303
Ağırlık : 750 gr/m

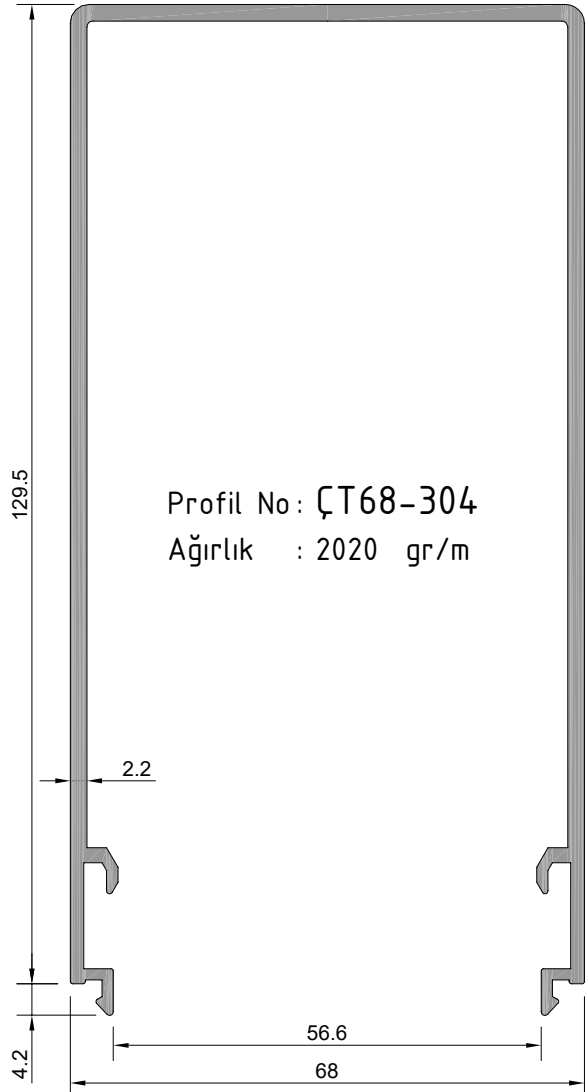

Profil No: ÇT68-304
Ağırlık : 2020 gr/m

ÇT68
ÇELİK TAKVİYELİ CEPHE
STEEL REINFORCED FAÇADE

ÜRÜN TEKNİK ÖZELLİKLERİ
PRODUCT'S TECHNICAL FEATURES

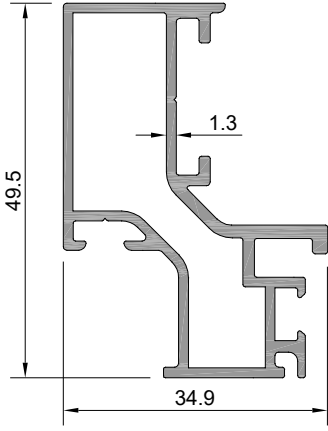

Profil No: SC0201
Ağırlık : 734 gr/m



SC0308-a



SC0304-a



SC0307-a

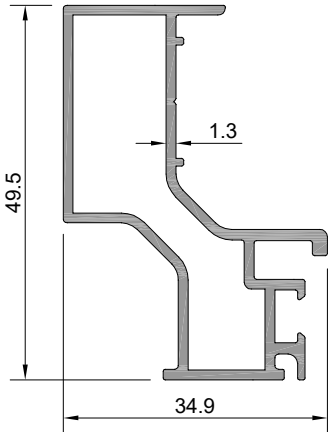

Profil No: SC0202
Ağırlık : 636 gr/m



SC0308-a



SC0304-a



SC0307-a

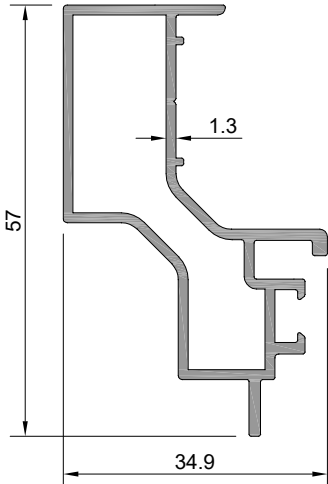

Profil No: SC0203
Ağırlık : 643 gr/m



SC0308-a



SC0304-a



SC0307-a

ÇT68
ÇELİK TAKVİYELİ CEPHE
STEEL REINFORCED FACADE

ÜRÜN TEKNİK ÖZELLİKLERİ
PRODUCT'S TECHNICAL FEATURES

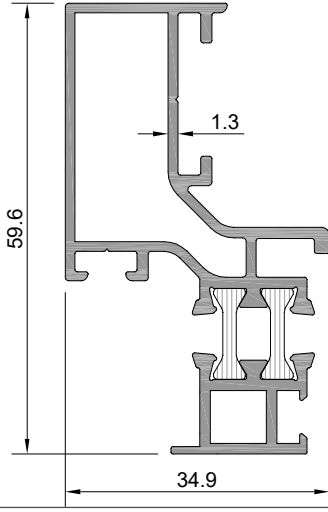

Profil No: ŞC0204

Ağırlık PVC : 970 gr/m

Ağırlık POLY: 963 gr/m



SC0308-b



SC0304-a



SC0309-a

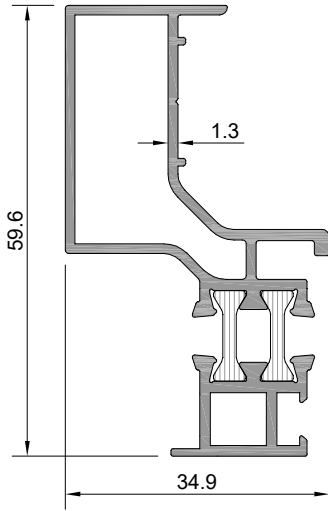

Profil No: ŞC0205

Ağırlık PVC : 894 gr/m

Ağırlık POLY: 886 gr/m



SC0308-b



SC0304-a



SC0309-a

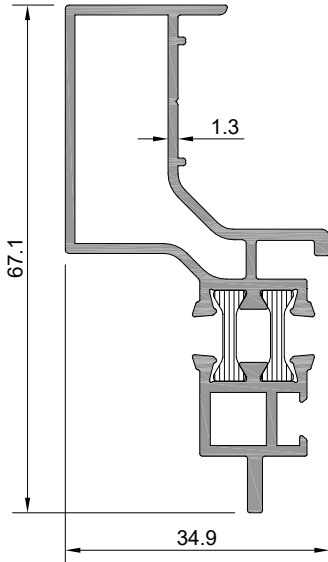

Profil No: ŞC0206

Ağırlık PVC : 924 gr/m

Ağırlık POLY: 916 gr/m



SC0308-b

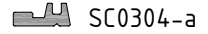

SC0304-a



SC0309-a

ÇT68
ÇELİK TAKVİYELİ CEPHE
STEEL REINFORCED FACADE

ÜRÜN TEKNİK ÖZELLİKLERİ
PRODUCT'S TECHNICAL FEATURES

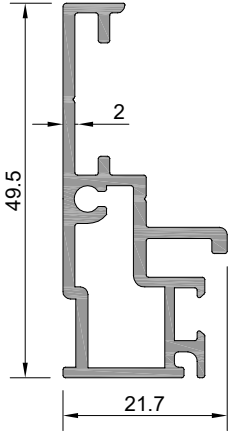

Profil No: SC0209
Ağırlık : 593 gr/m

 SC0304-a

 SC0307-a

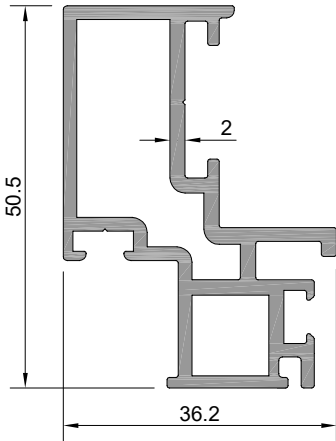

Profil No: SC0210
Ağırlık : 1001 gr/m

 SC0308-a

 SC0304-a

 SC0307-a

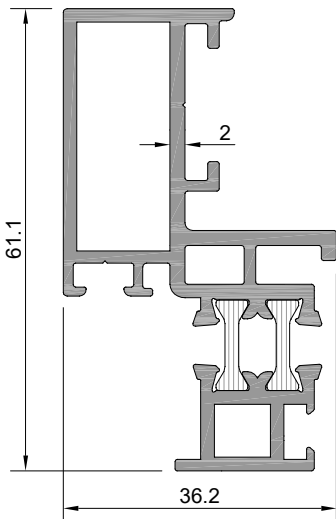

Profil No: SC0214

Ağırlık PVC : 1275 gr/m

Ağırlık POLY : 1268 gr/m

 SC0308-b

 SC0304-a

 SC0309-a

ÇT68
ÇELİK TAKVİYELİ CEPHE
STEEL REINFORCED FACADE

ÜRÜN TEKNİK ÖZELLİKLERİ
PRODUCT'S TECHNICAL FEATURES

Profil No: SC0215

Ağırlık PVC : 1365 gr/m

Ağırlık POLY: 1350 gr/m

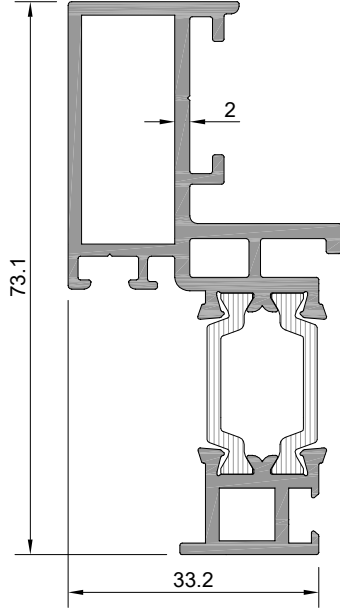

Profil No: SC0216

Ağırlık PVC : 1060 gr/m

Ağırlık POLY: 1045 gr/m

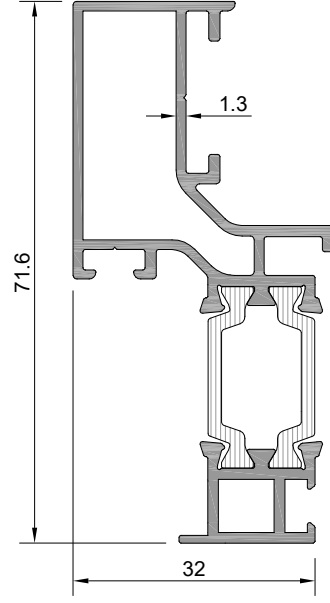

SC0308-b

SC0304-a



SC0309-a



SC0308-b

SC0304-a



SC0309-a

Profil No: SC0218

Ağırlık : 1250 gr/m

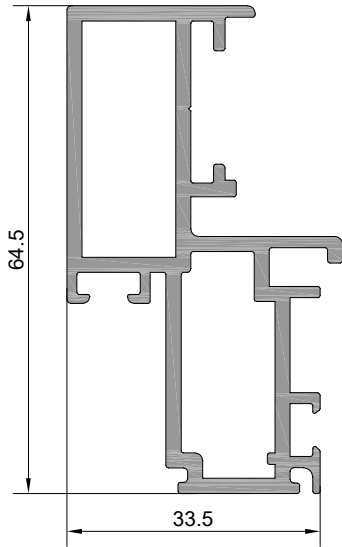

Profil No: SC0219

Ağırlık PVC : 1449 gr/m

Ağırlık POLY: 1442 gr/m

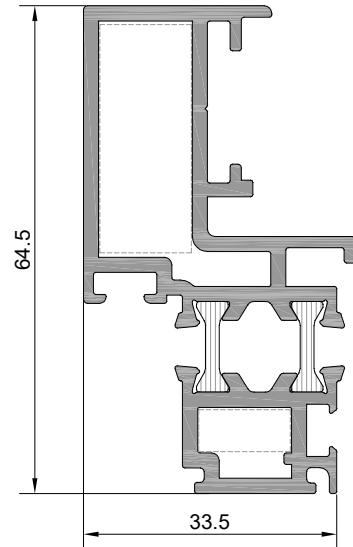

SC0308-b

SC0304-a



SC0308-g



SC0308-b

SC0304-a



SC0308-l

Profil değerleri teoriktir. Ağırlık olarak testimde yapılan tartım geçerlidir.
Profil imalatları TS EN 12020-2 ve TS EN 755-9 toleransı,
Moment değerleri EN 14024'e göre hesaplanmıştır.

Profile values are theoretical pre-shipment weight will be valid.
The tolerances of Profile manufacturing are calculated according to EN 12020-2
and TS EN 755-9; moment values are calculated according to EN 14024.

ÇT68
ÇELİK TAKVİYELİ CEPHE
STEEL REINFORCED FACADE

PANEL CAM KOMBİNASYONU
GLASS PANEL COMBINATION

SC0201

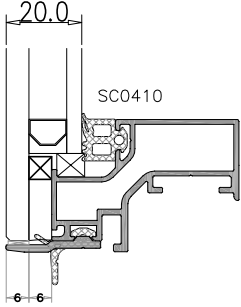

SC0210

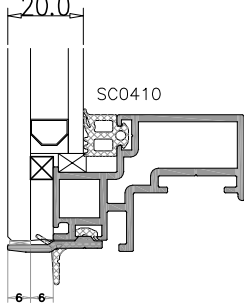

SC0204

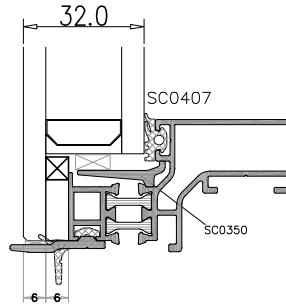

SC0214

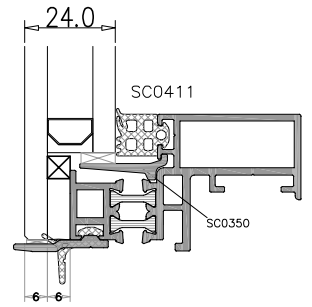
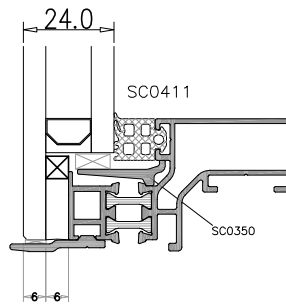
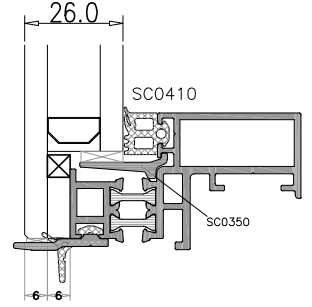
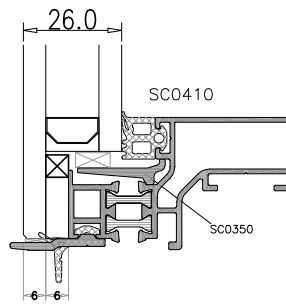
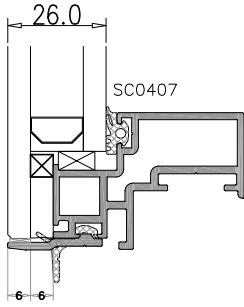
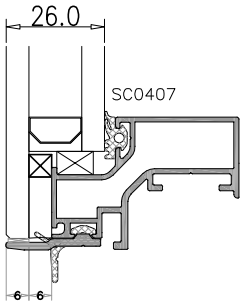
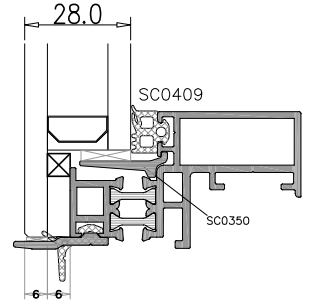
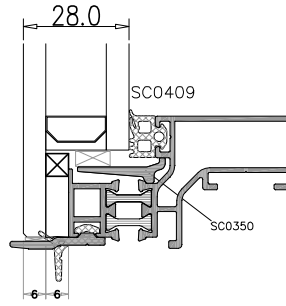
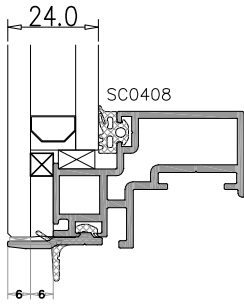
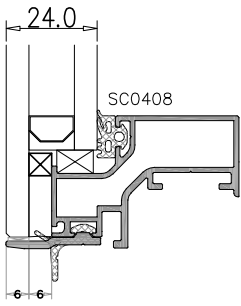
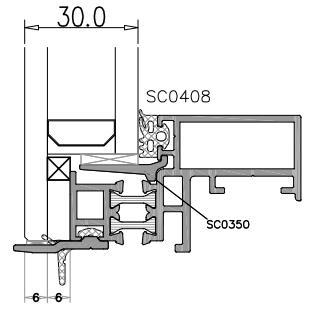
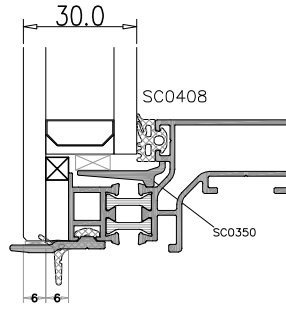
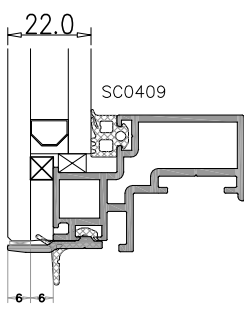
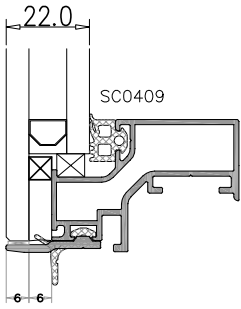
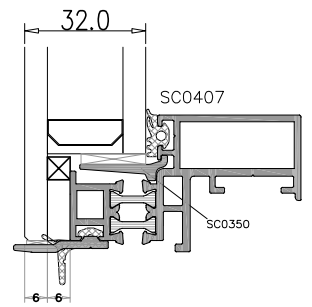

ÇT68
ÇELİK TAKVİYELİ CEPHE
STEEL REINFORCED FACADE

PANEL CAM KOMBİNASYONU
GLASS PANEL COMBINATION

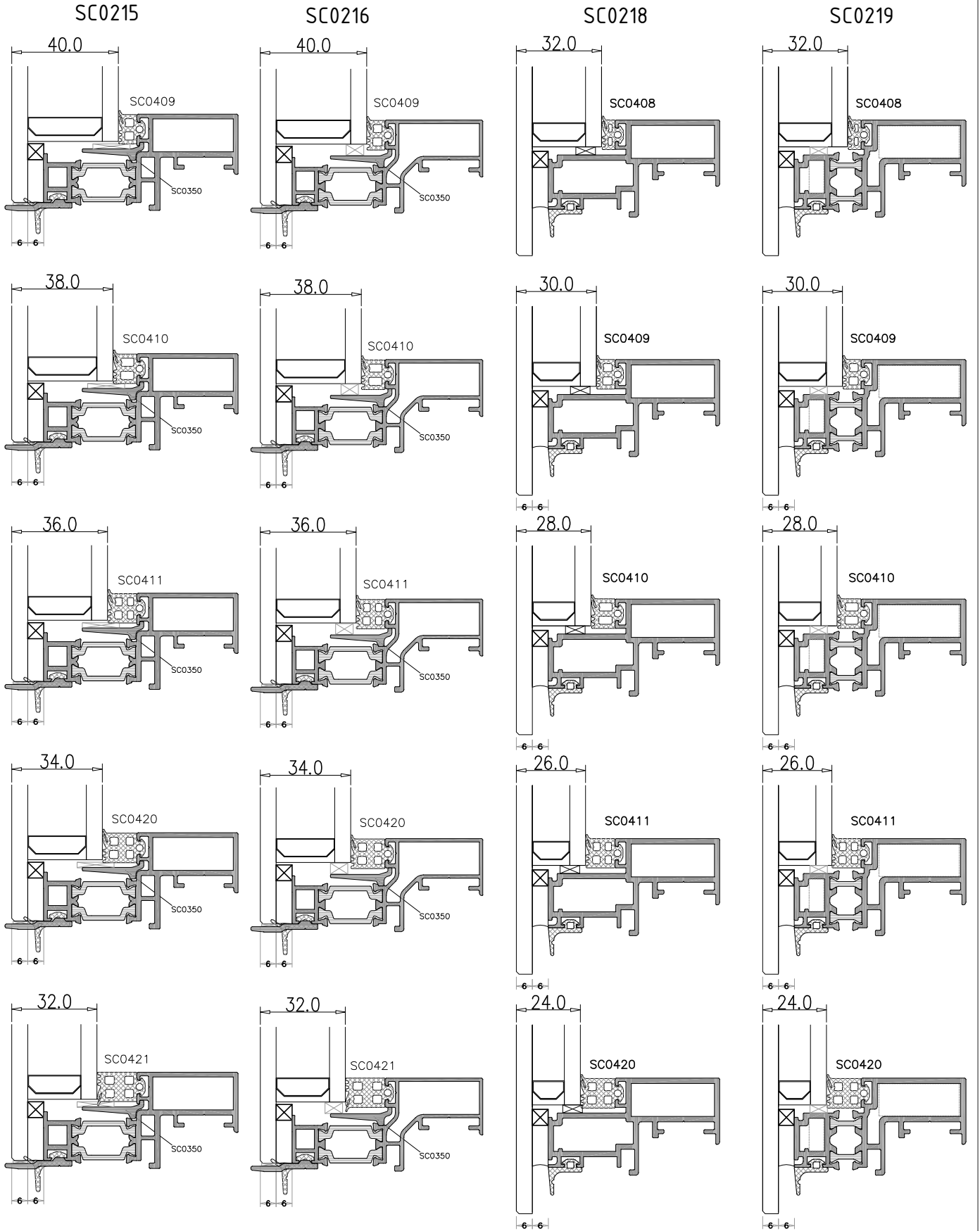

Profil değerleri teoriktir. Ağırlık olarak testimde yapılan tartım geçerlidir.
Profil imalatları TS EN 12020-2 ve TS EN 755-9 toleransı,
Moment değerleri EN 14024'e göre hesaplanmıştır.

Profile values are theoretical pre-shipment weight will be valid.
The tolerances of Profile manufacturing are calculated according to EN 12020-2
and TS EN 755-9; moment values are calculated according to EN 14024.

ÇT68
ÇELİK TAKVİYELİ CEPHE
STEEL REINFORCED FACADE

ÜRÜN TEKNİK ÖZELLİKLERİ
PRODUCT'S TECHNICAL FEATURES

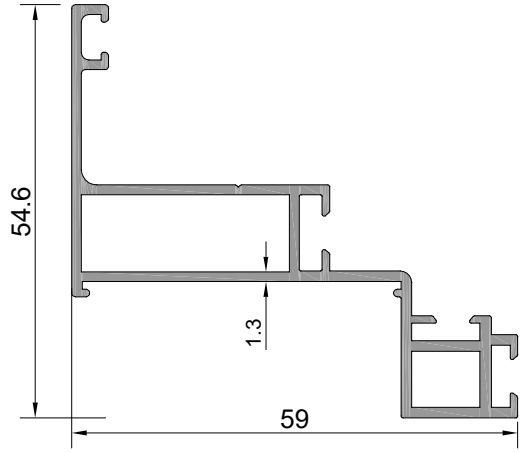

Profil No : KC0201
Ağırlık : 737 gr/m

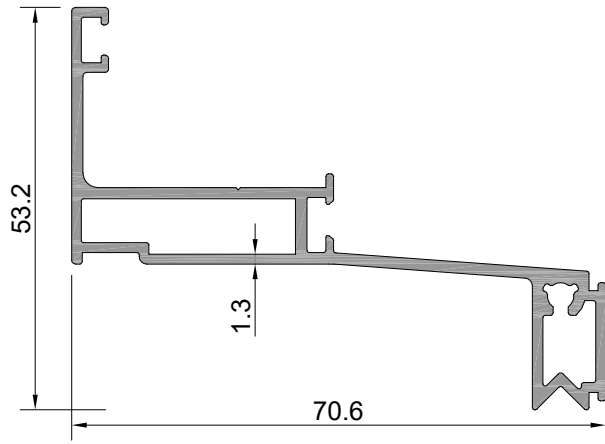

Profil No : KC0202
Ağırlık : 792 gr/m

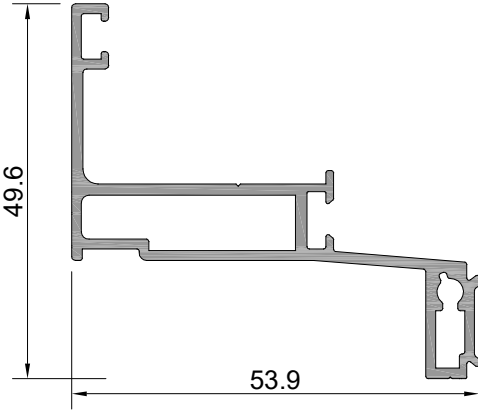

Profil No : KC0203
Ağırlık : 662 gr/m

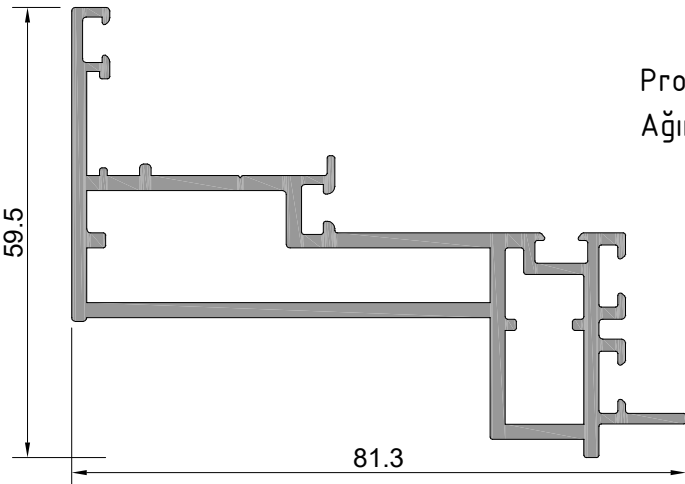

Profil No : KC0204
Ağırlık : 1463 gr/m



ÇT68
ÇELİK TAKVİYELİ CEPHE
STEEL REINFORCED FACADE

ÜRÜN TEKNİK ÖZELLİKLERİ
PRODUCT'S TECHNICAL FEATURES

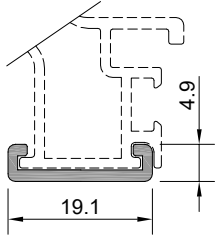

Profil No: SC0207
Ağırlık : 109 gr/m

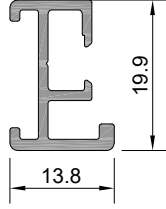

Profil No: SC0217
Ağırlık : 242 gr/m

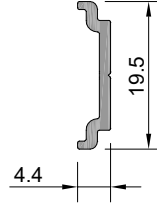

Profil No: SC0303
Ağırlık : 96 gr/m

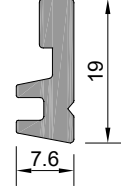

Profil No: SC0304
Ağırlık : 238 gr/m

SC0304-a	50 mm	100 adet/pcs
----------	-------	--------------

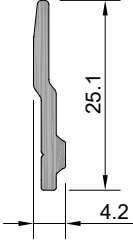

Profil No: SC0312
Ağırlık : 147 gr/m

SC0312-a	50 mm	100 adet/pcs
----------	-------	--------------

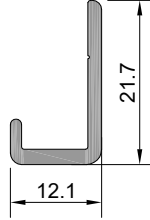

Profil No: SC0343
Ağırlık : 173 gr/m

SC0343-a	50 mm	100 adet/pcs
----------	-------	--------------

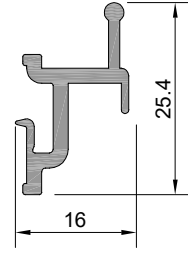

Profil No: SC0344
Ağırlık : 244 gr/m

SC0344-a	50 mm	100 adet/pcs
----------	-------	--------------

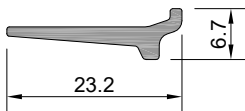

Profil No: SC0350
Ağırlık : 140 gr/m

SC0350-a	50 mm	100 adet/pcs
----------	-------	--------------

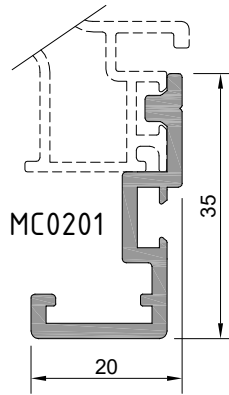

Profil No: MC0201
Ağırlık : 397 gr/m

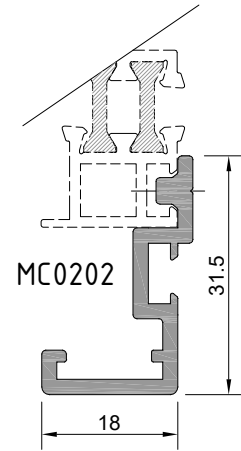

Profil No: MC0202
Ağırlık : 378 gr/m

ÇT68
ÇELİK TAKVİYELİ CEPHE
STEEL REINFORCED FACADE

ÜRÜN TEKNİK ÖZELLİKLERİ
PRODUCT'S TECHNICAL FEATURES

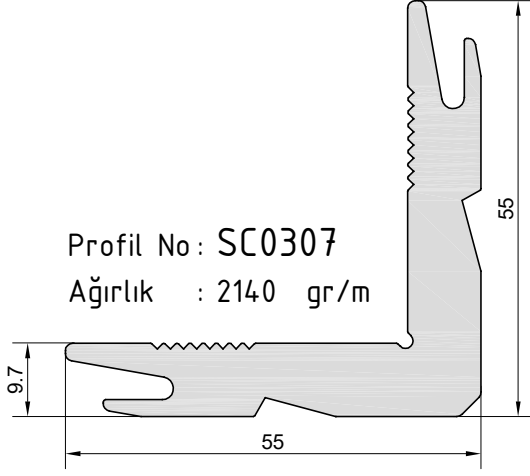

Profil No : SC0307
Ağırlık : 2140 gr/m

SC0307-a	10.25mm	100 adet/pcs
SC0307-b	27mm	100 adet/pcs
SC0307-c	8.5mm	100 adet/pcs
SC0307-d	23.9mm	100 adet/pcs
SC0307-e	6.3mm	100 adet/pcs

SC0307-f	25.6mm	100 adet/pcs
SC0307-g	6mm	100 adet/pcs
SC0307-h	4.7mm	100 adet/pcs
SC0307-ı	26.28mm	100 adet/pcs
SC0307-j	29.5mm	100 adet/pcs

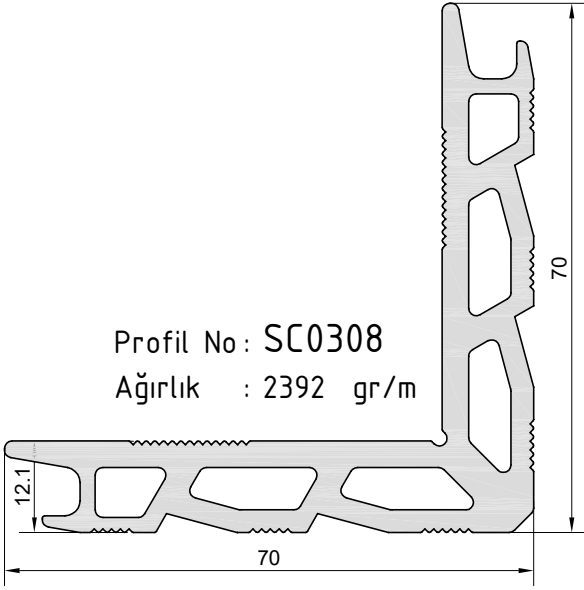

Profil No : SC0308
Ağırlık : 2392 gr/m

SC0308-a	25.68mm	100 adet/pcs
SC0308-b	29.74mm	100 adet/pcs
SC0308-c	24.36mm	100 adet/pcs
SC0308-d	10.30mm	100 adet/pcs
SC0308-e	6.70mm	100 adet/pcs
SC0308-f	23mm	100 adet/pcs
SC0308-g	19.50mm	100 adet/pcs

SC0308-h	9.9mm	100 adet/pcs
SC0308-j	9.2mm	100 adet/pcs
SC0308-k	39mm	100 adet/pcs
SC0308-l	5.6mm	100 adet/pcs

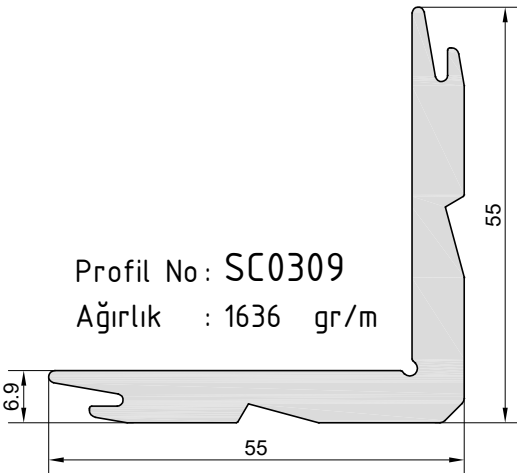

Profil No : SC0309
Ağırlık : 1636 gr/m

SC0309-a	6.5mm	100 adet/pcs
SC0309-b	8.5mm	100 adet/pcs
SC0309-c	18.9mm	100 adet/pcs
SC0309-d	20mm	100 adet/pcs
SC0309-e	25.3mm	100 adet/pcs

SC0309-f	4.7mm	100 adet/pcs
SC0309-g	54.2mm	100 adet/pcs
SC0309-h	23.8mm	100 adet/pcs
SC0309-ı	48.2mm	100 adet/pcs
SC0309-j	52.8mm	100 adet/pcs

ÇT68
ÇELİK TAKVİYELİ CEPHE
STEEL REINFORCED FAÇADE

ÜRÜN TEKNİK ÖZELLİKLERİ
PRODUCT'S TECHNICAL FEATURES

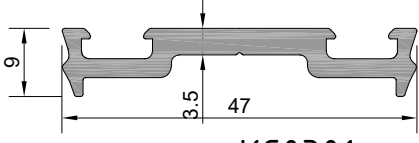

Profil No: KC0301
Ağırlık : 496 gr/m

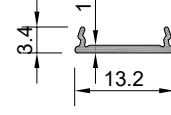

Profil No: KC0325
Ağırlık : 43 gr/m

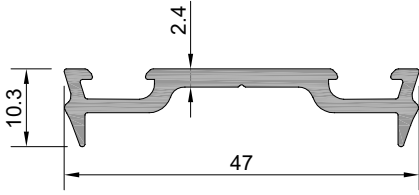

Profil No: KC0302
Ağırlık : 395 gr/m

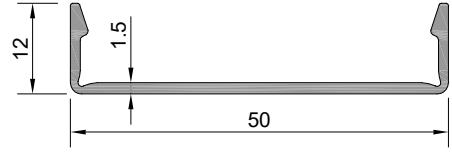

Profil No: KC0309
Ağırlık : 283 gr/m

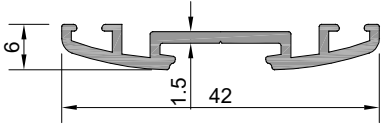

Profil No: KC0323
Ağırlık : 261 gr/m

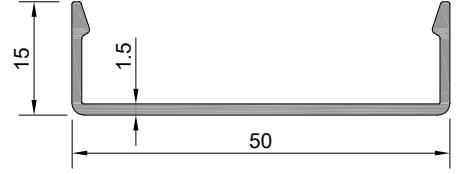

Profil No: KC0310
Ağırlık : 308 gr/m

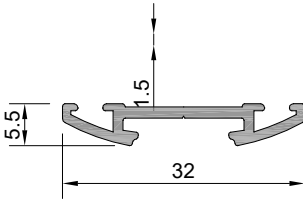

Profil No: KC0324
Ağırlık : 186 gr/m

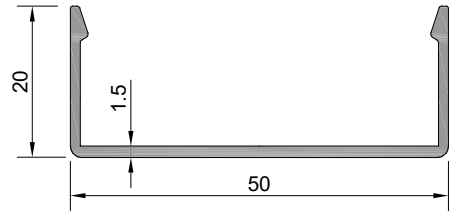

Profil No: KC0306
Ağırlık : 343 gr/m

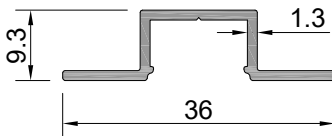

Profil No: KC0346
Ağırlık : 183 gr/m

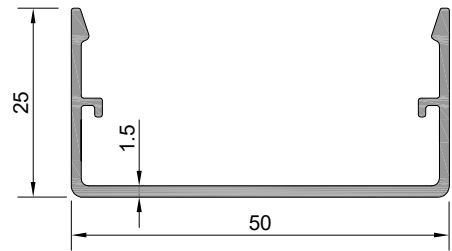

Profil No: KC0311
Ağırlık : 403 gr/m

ÇT68
ÇELİK TAKVİYELİ CEPHE
STEEL REINFORCED FAÇADE

ÜRÜN TEKNİK ÖZELLİKLERİ
PRODUCT'S TECHNICAL FEATURES

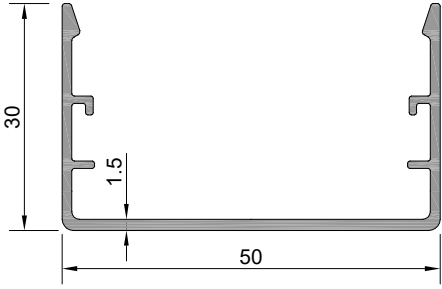

Profil No : KC0312
Ağırlık : 455 gr/m

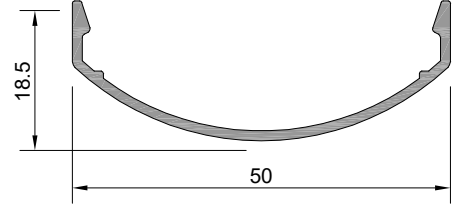

Profil No : KC0322
Ağırlık : 262 gr/m

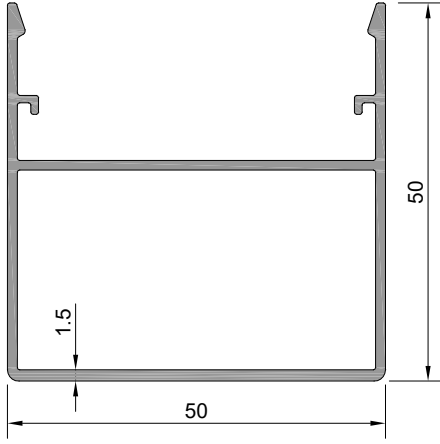

Profil No : KC0313
Ağırlık : 745 gr/m

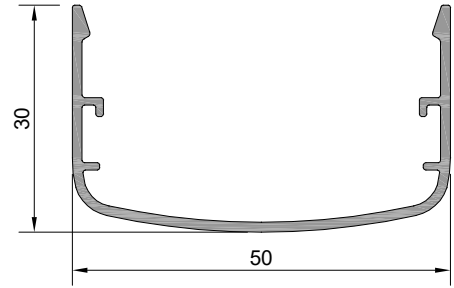

Profil No : KC0315
Ağırlık : 397 gr/m

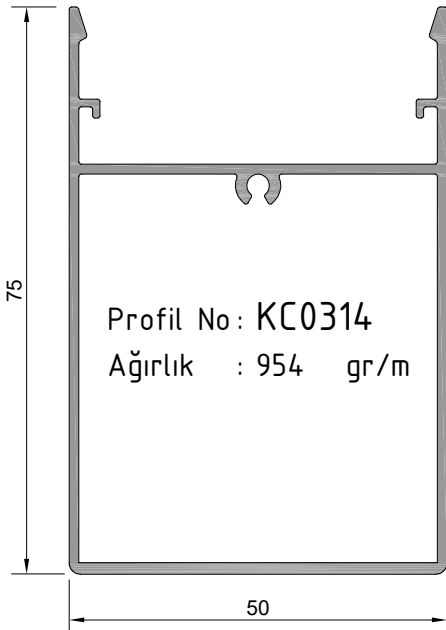

Profil No : KC0314
Ağırlık : 954 gr/m

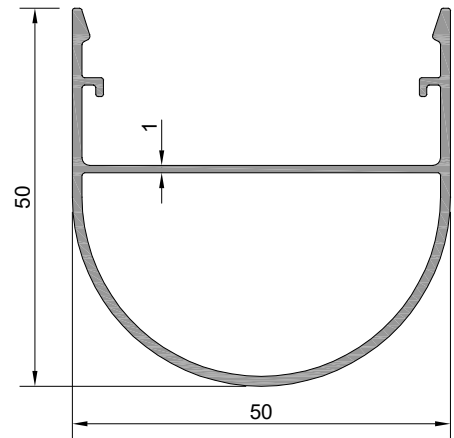

Profil No : KC0316
Ağırlık : 611 gr/m

ÇT68
ÇELİK TAKVİYELİ CEPHE
STEEL REINFORCED FAÇADE

ÜRÜN TEKNİK ÖZELLİKLERİ
PRODUCT'S TECHNICAL FEATURES

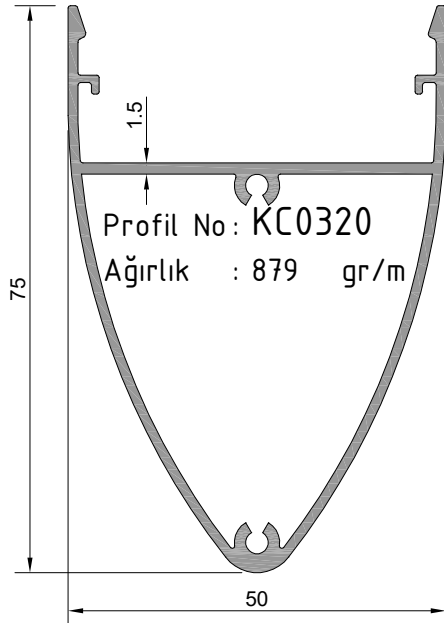
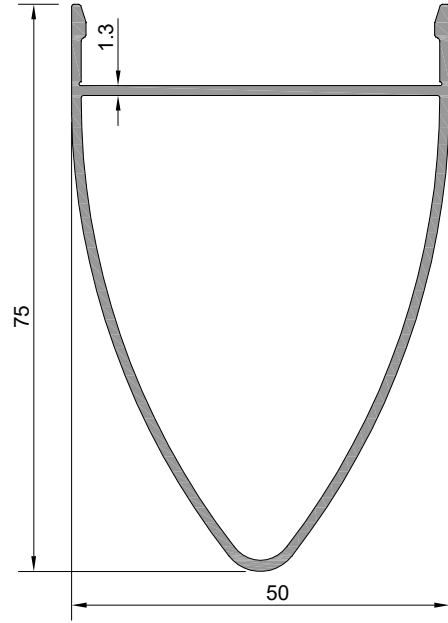
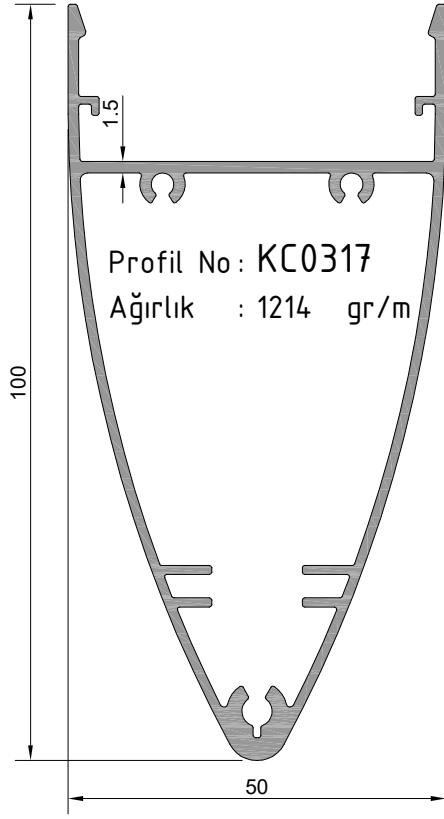

ÇT68
ÇELİK TAKVİYELİ CEPHE
STEEL REINFORCED FACADE

ÜRÜN TEKNİK ÖZELLİKLERİ
PRODUCT'S TECHNICAL FEATURES

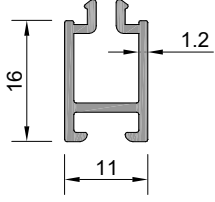

Profil No: KC0333
Ağırlık : 183 gr/m

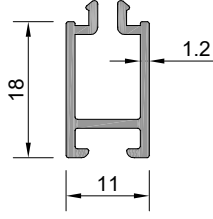

Profil No: KC0334
Ağırlık : 196 gr/m

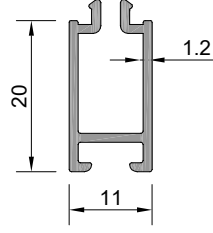

Profil No: KC0331
Ağırlık : 209 gr/m

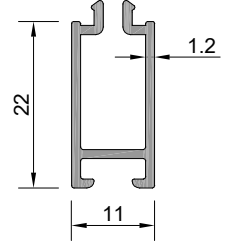

Profil No: KC0332
Ağırlık : 222 gr/m

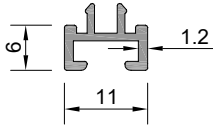

Profil No: KC0350
Ağırlık : 96 gr/m

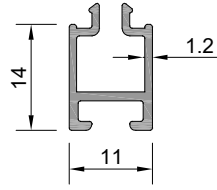

Profil No: KC0351
Ağırlık : 154 gr/m

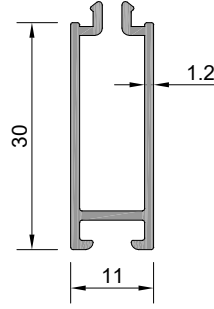

Profil No: KC0352 
Ağırlık : 274 gr/m

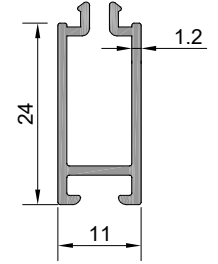

Profil No: KC0347
Ağırlık : 235 gr/m

 İşaretili profil için satış ekibinden bilgi almız.

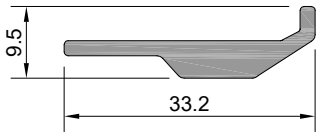

Profil No: KC0336
Ağırlık : 305 gr/m

KC0336-a	50 mm	100 adet/pcs
----------	-------	--------------

ÇT68
ÇELİK TAKVİYELİ CEPHE
STEEL REINFORCED FACADE

SABİT - SABİT
FIXED-FIXED

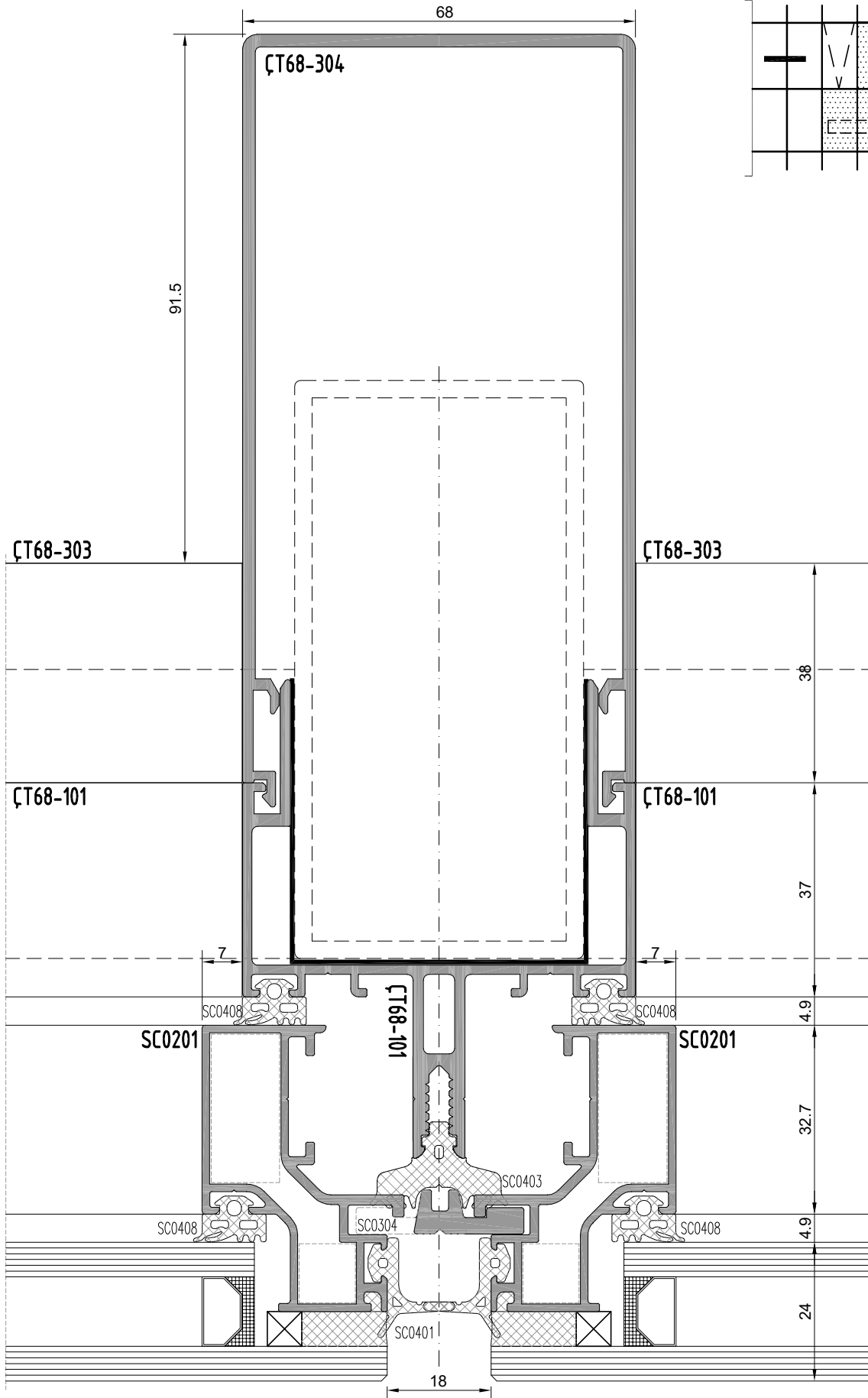

ÇT68
ÇELİK TAKVİYELİ CEPHE
STEEL REINFORCED FACADE

SABİT - KANAT
FIXED-SASH

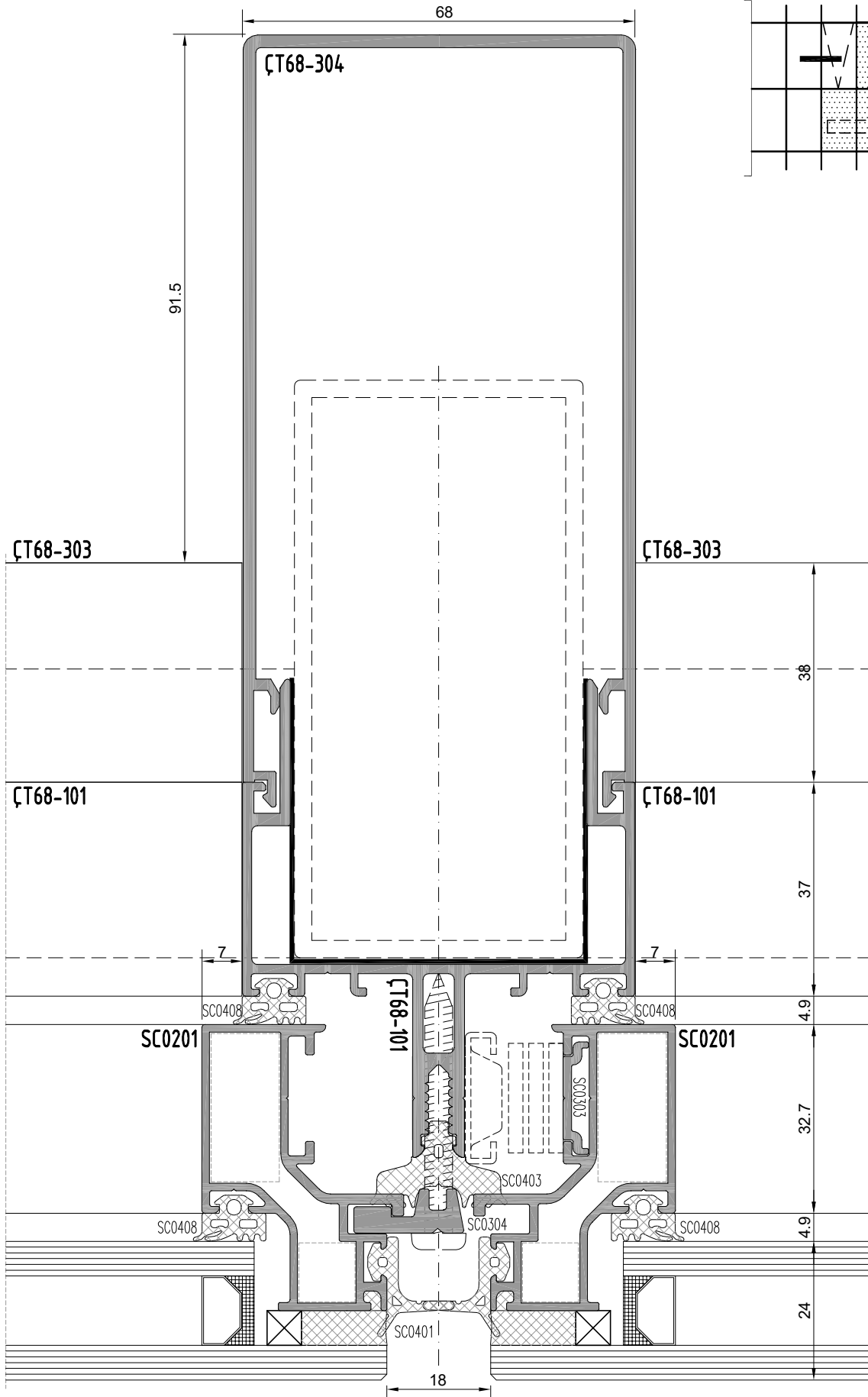

ÇT68
ÇELİK TAKVİYELİ CEPHE
STEEL REINFORCED FACADE

SABİT - KANAT
FIXED-SASH

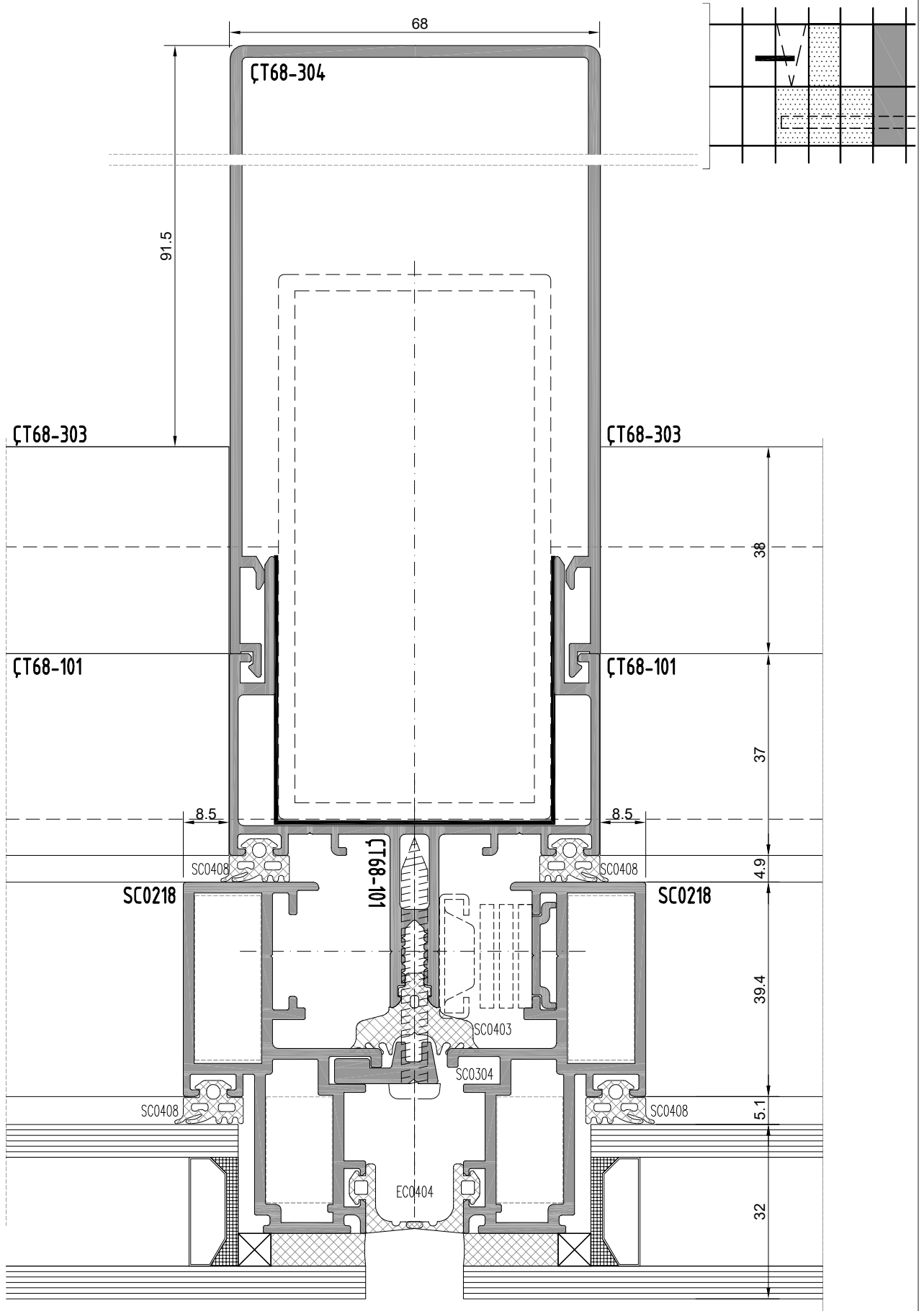

ÇT68
ÇELİK TAKVİYELİ CEPHE
STEEL REINFORCED FACADE

SABİT - KANAT
FIXED-SASH

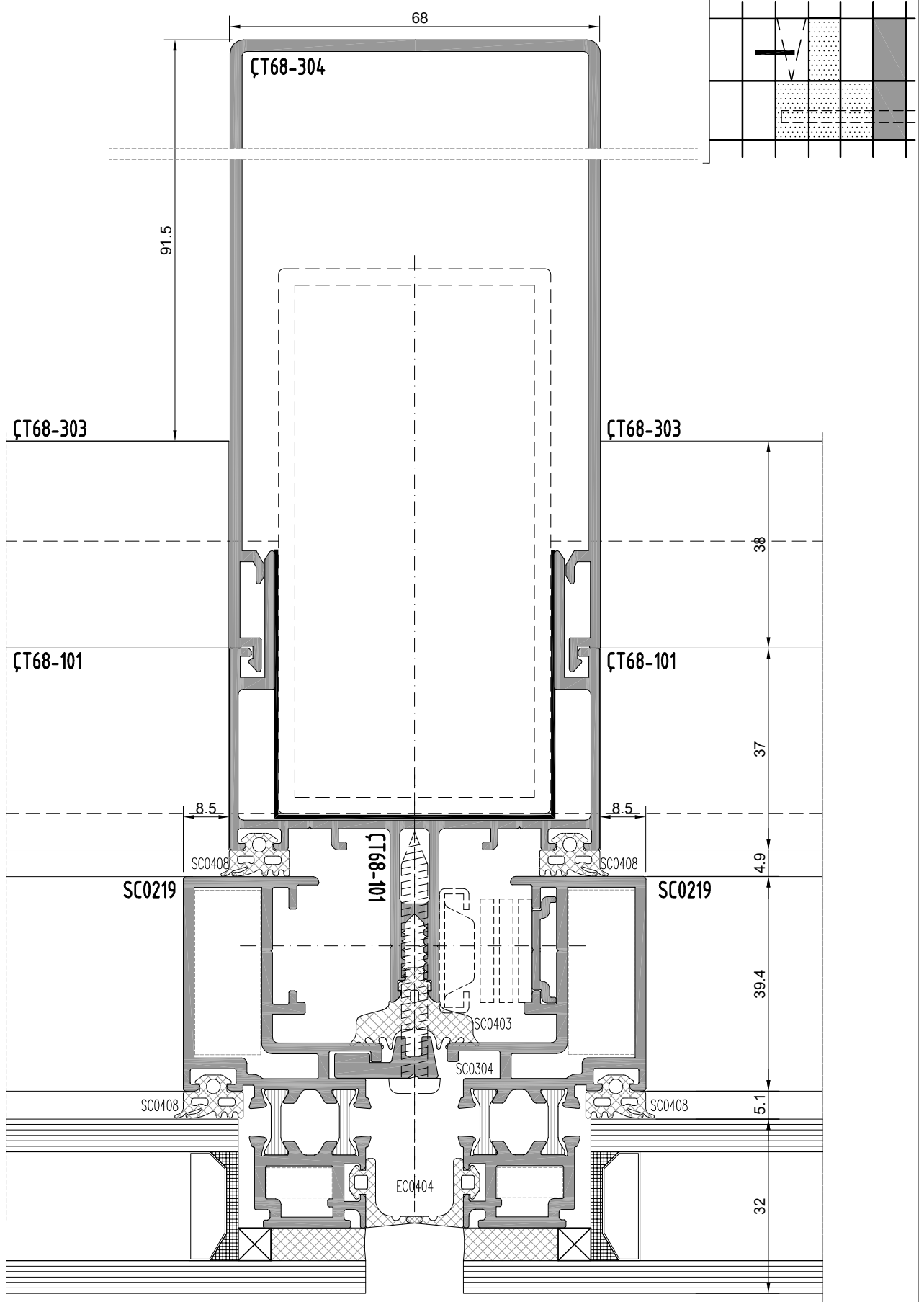

ÇT68
ÇELİK TAKVİYELİ CEPHE
STEEL REINFORCED FACADE

SABİT - SABİT
FIXED-FIXED

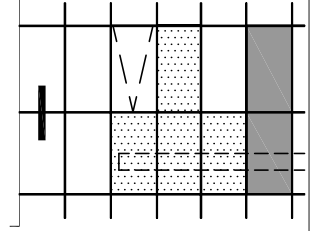

ÇT68-304

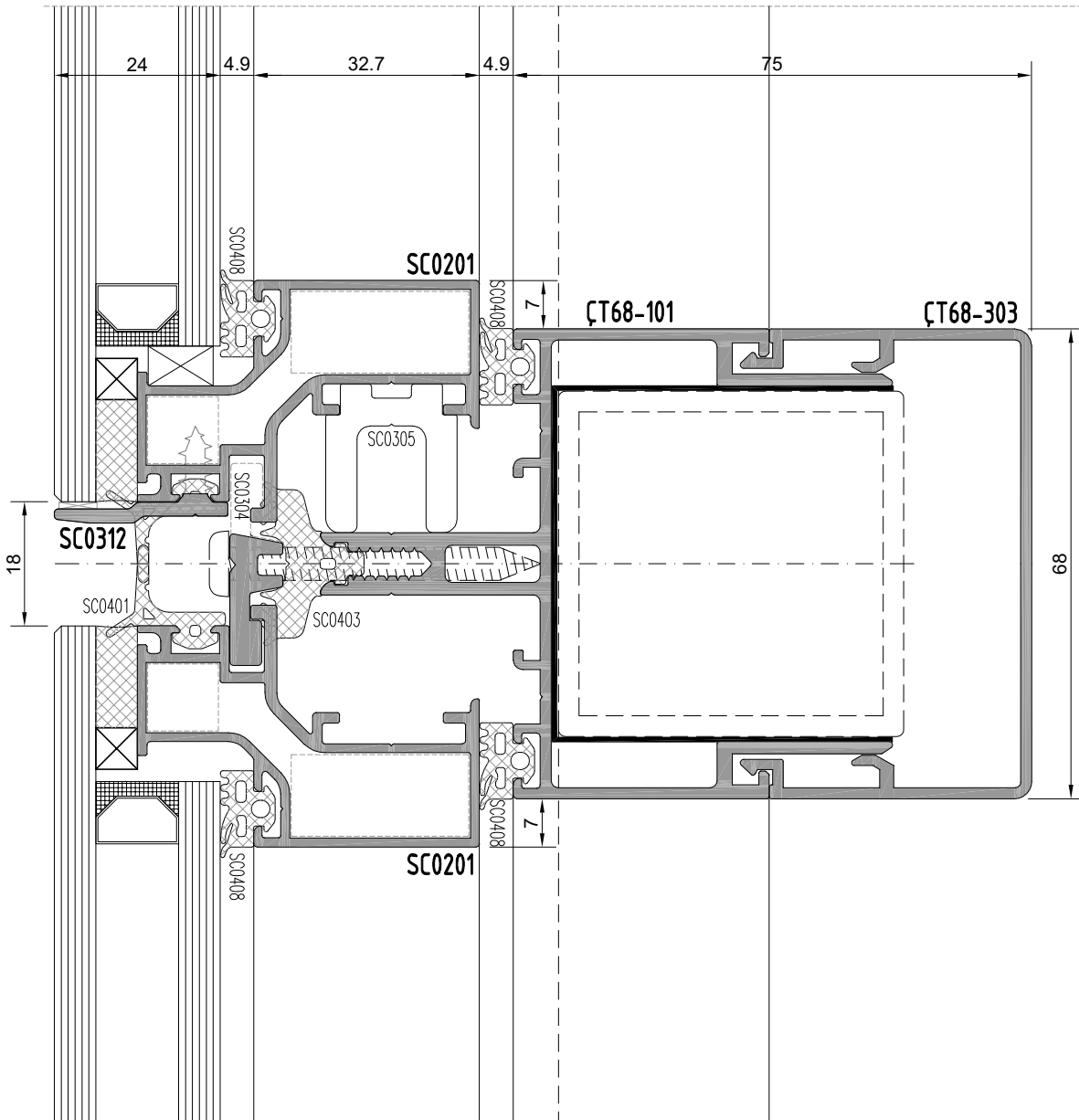

ÇT68
ÇELİK TAKVİYELİ CEPHE
STEEL REINFORCED FACADE

KANAT - SPANDREL
SASH-SPANDREL

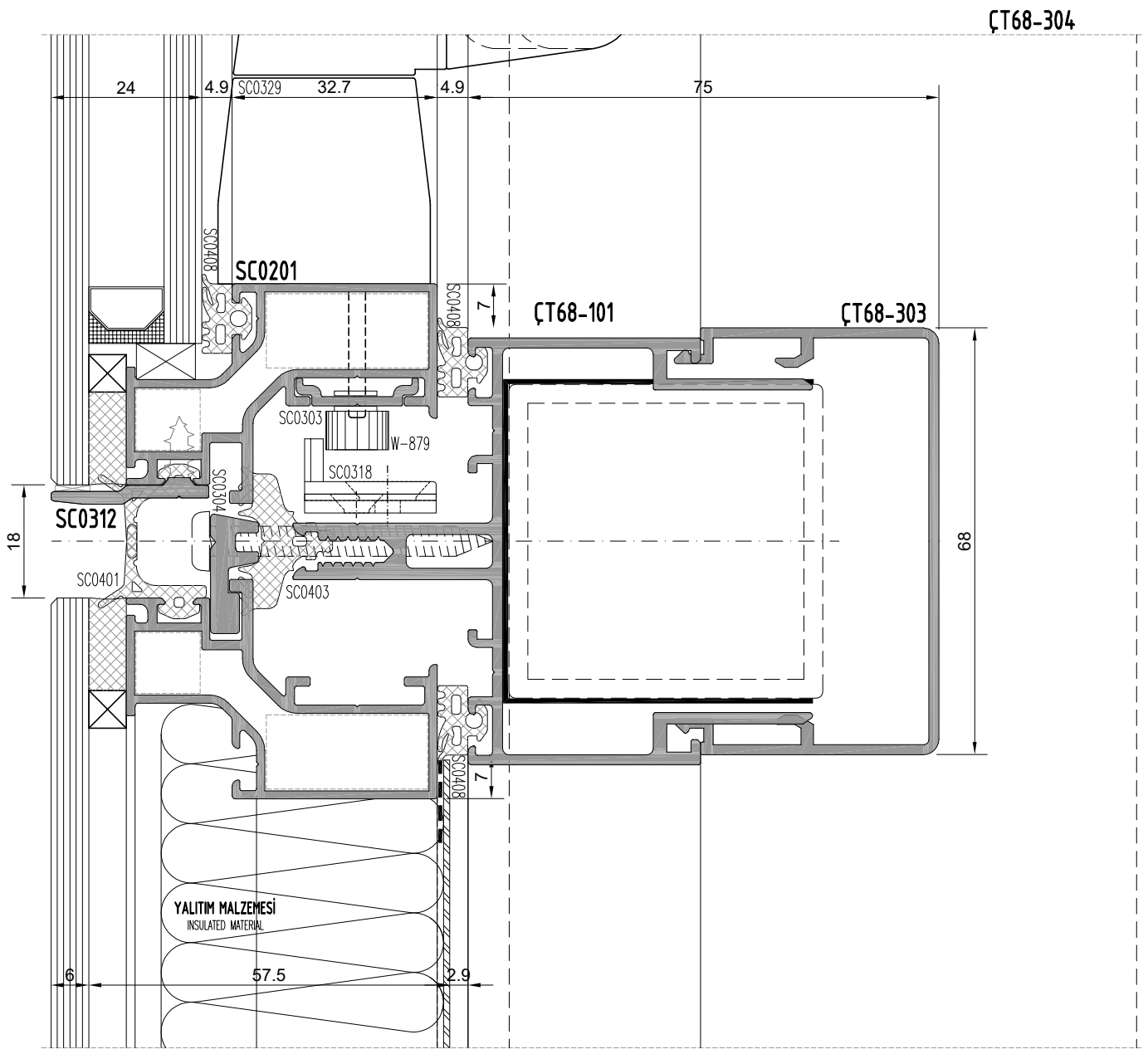
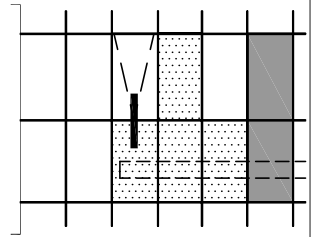

ÇT68
ÇELİK TAKVİYELİ CEPHE
STEEL REINFORCED FACADE

KANAT - SPANDREL
SASH-SPANDREL

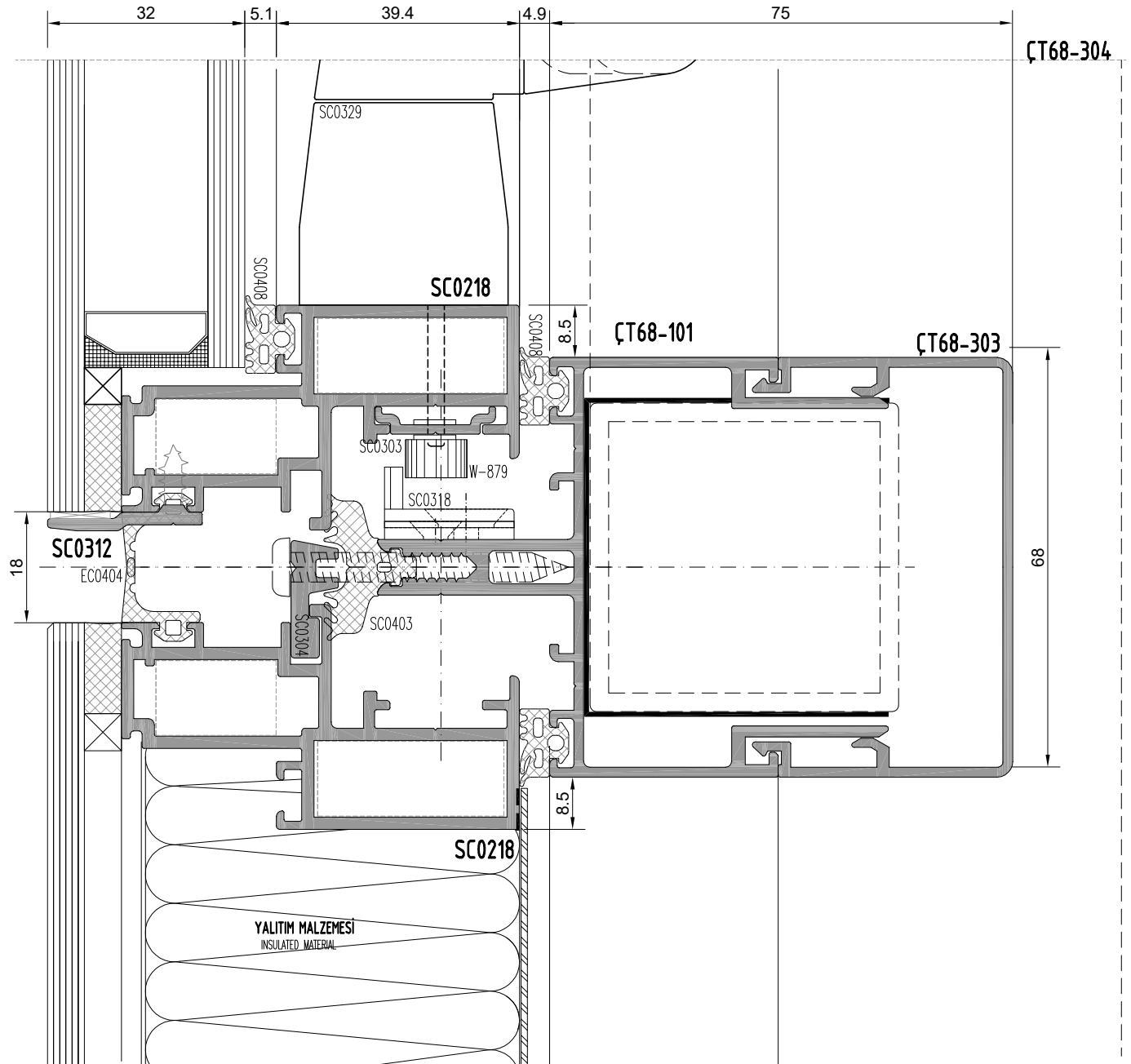
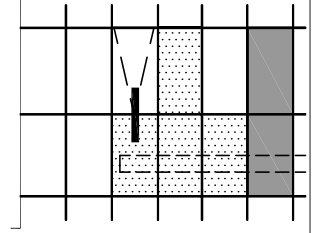

ÇT68
ÇELİK TAKVİYELİ CEPHE
STEEL REINFORCED FACADE

KANAT - SPANDREL
SASH-SPANDREL

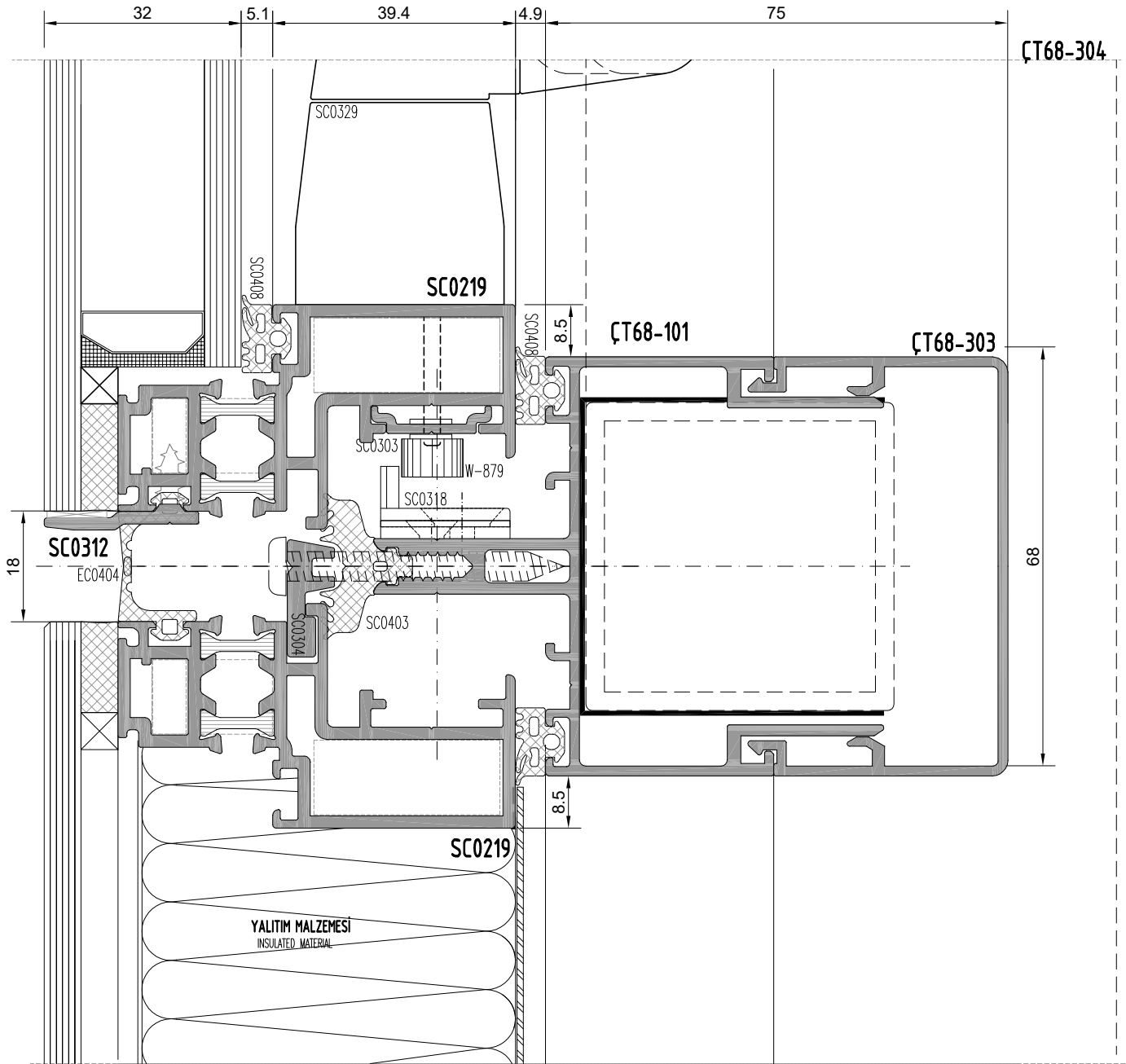
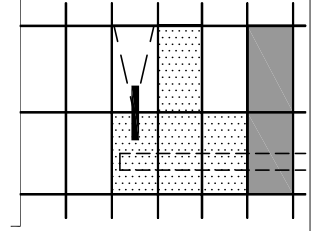

ÇT68
ÇELİK TAKVİYELİ CEPHE
STEEL REINFORCED FACADE

SABİT - SABİT
FIXED-FIXED

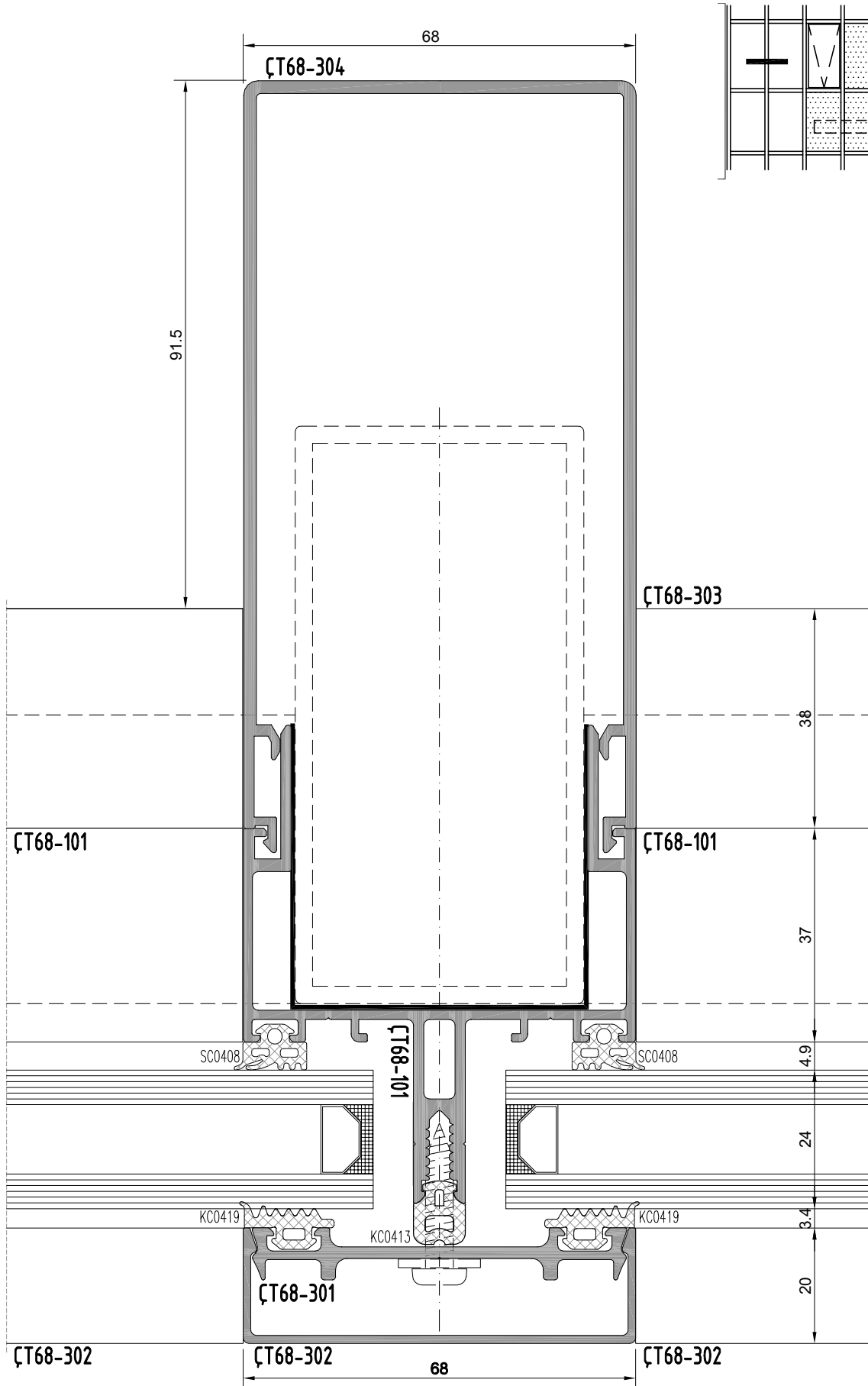

ÇT68
ÇELİK TAKVİYELİ CEPHE
STEEL REINFORCED FACADE

SABİT - KANAT
FIXED-SASH

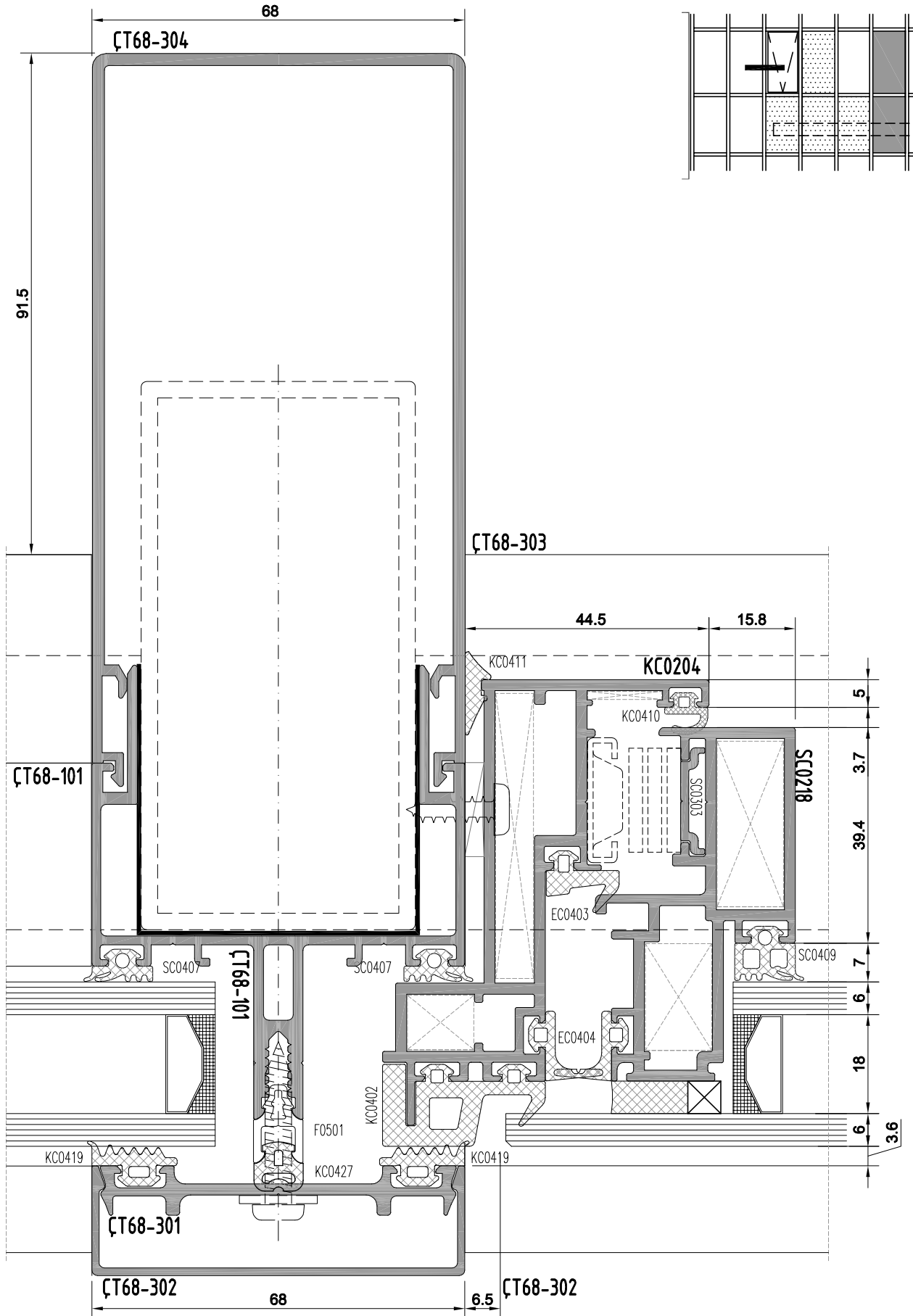

ÇT68
ÇELİK TAKVİYELİ CEPHE
STEEL REINFORCED FACADE

SABİT - SABİT
FIXED-FIXED

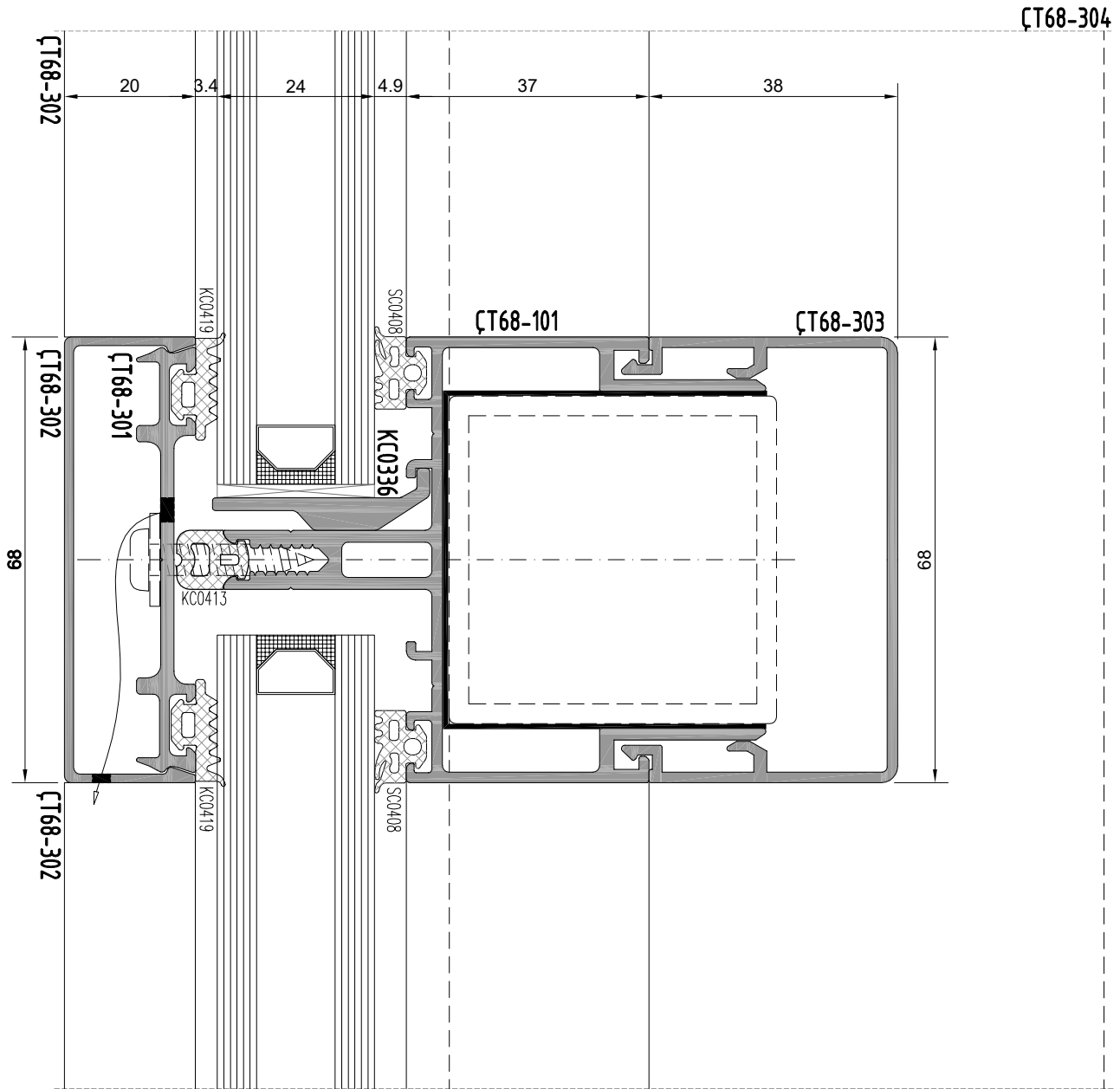
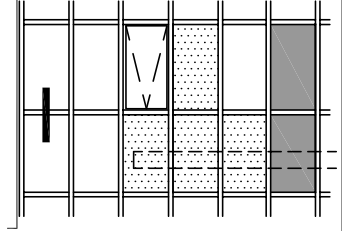

ÇT68
ÇELİK TAKVİYELİ CEPHE
STEEL REINFORCED FACADE

KANAT - SPANDEL
SASH-SPANDEL

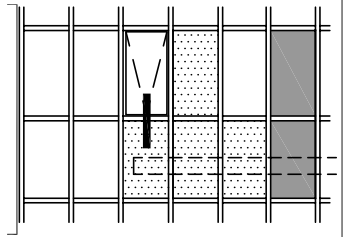

ÇT68-304

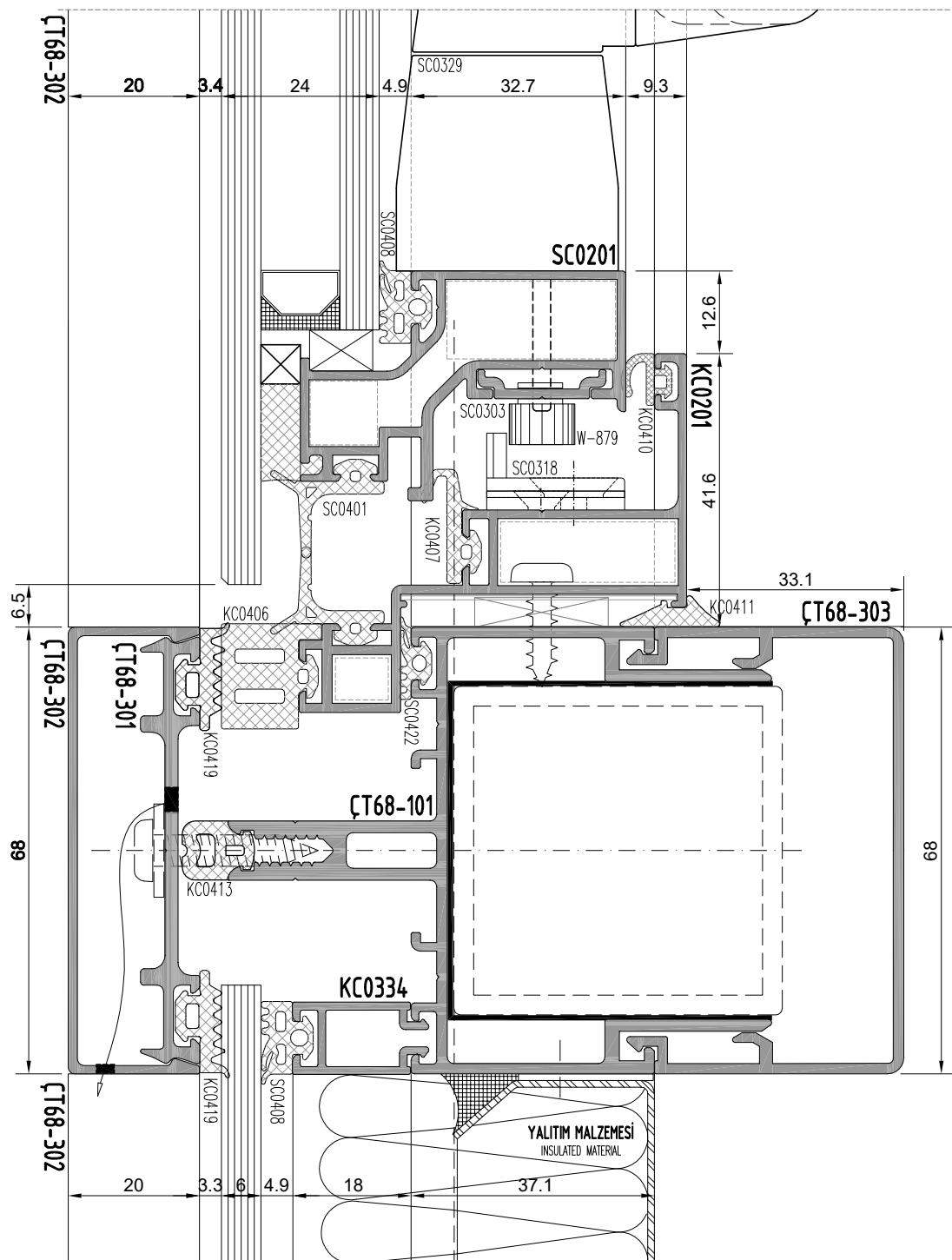

ÇT68
ÇELİK TAKVİYELİ CEPHE
STEEL REINFORCED FACADE

KANAT - SPANDREL
SASH-SPANDREL

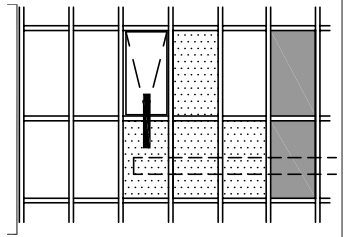

ÇT68-304

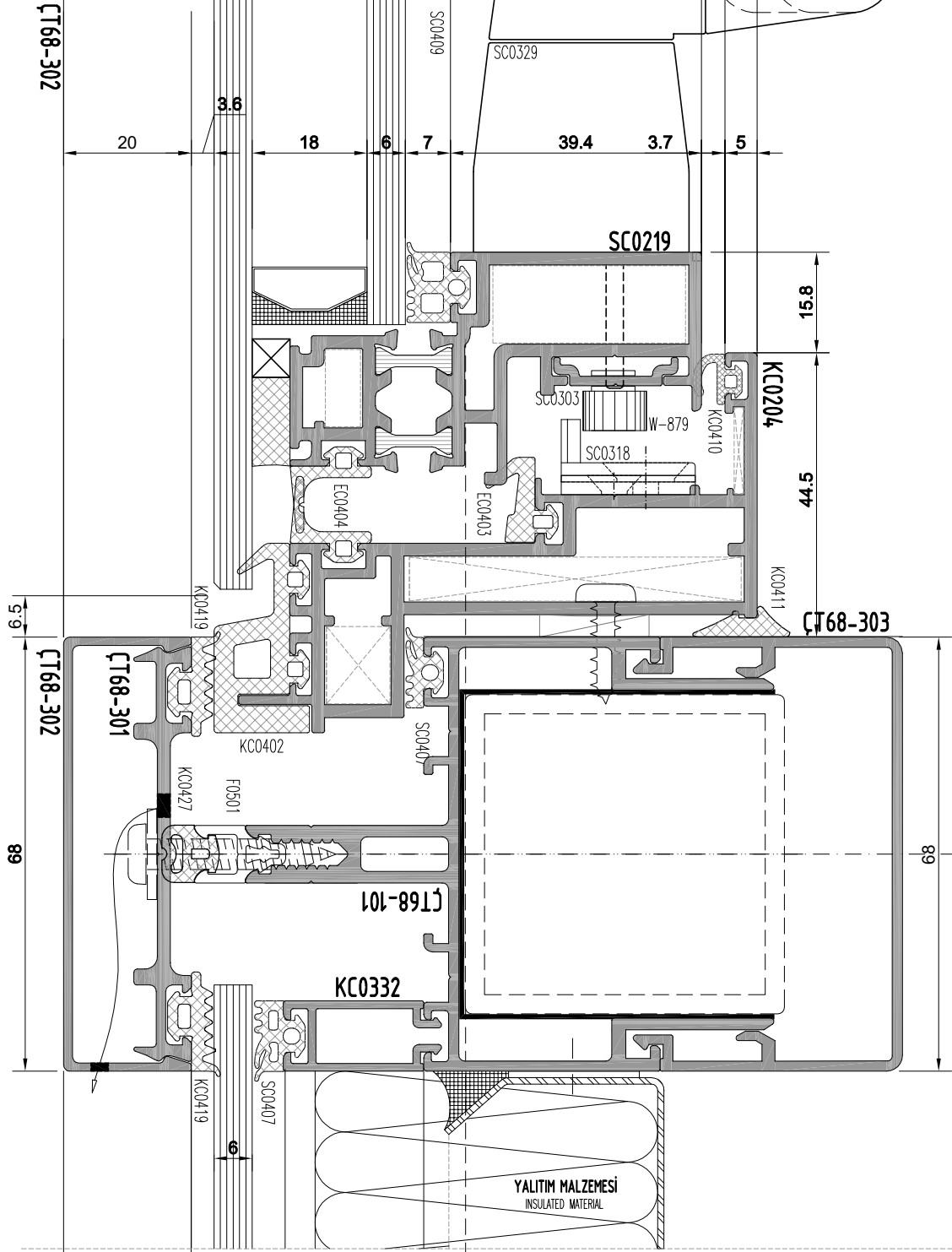

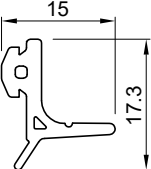
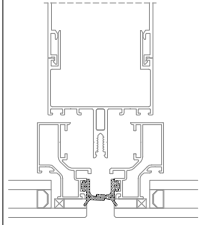
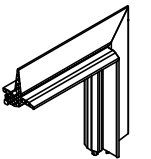
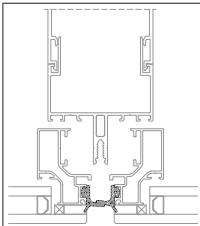
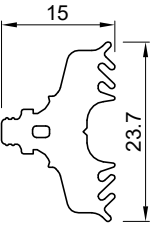
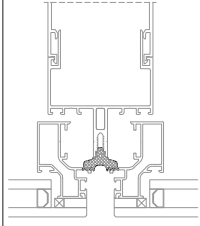
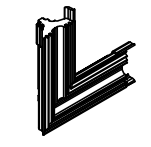
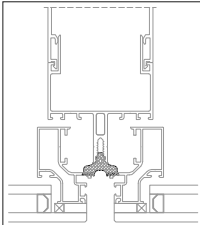
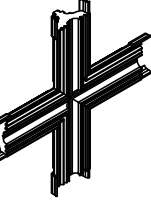
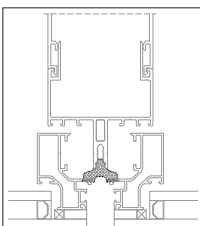
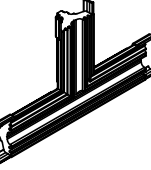
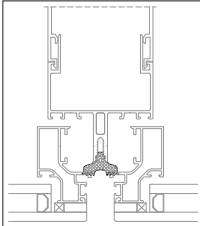
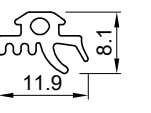
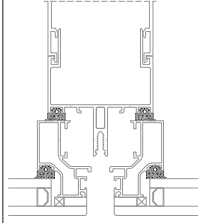

ÇT68
ÇELİK TAKVİYELİ CEPHE
STEEL REINFORCED FACADE

Fitil listesi
Gasket list

kod code	şekil drawing	tanım description	teorik ağırlık theoretical weight gr / m	paket ağırlığı package weight kg / package	paket metrajı in one package metre / package	kullanım yeri aplication
SC0401		Panel dış fitili Frame gasket	74 gr/m	15 kg	202 m	
SC0402		Panel dış fitili (köşe) Frame gasket (corner)	89 gr\m	-	50 ad-pcs	
SC0403		Taşıyıcı ön fitili Mullion or transom front gasket	173 gr/m	15 kg	76 m	
SC0404		Taşıyıcı ön fitili (L merkez) Mullion or transom front gasket (L center)	17.6 gr\ad	-	50 ad-pcs	
SC0405		Taşıyıcı ön fitili (T merkez) Mullion or transom front gasket (T center)	31.6 gr\ad	-	50 ad-pcs	
SC0406		Taşıyıcı ön fitili (+ merkez) Mullion or transom front gasket (+ center)	24.6 gr\ad	-	50 ad-pcs	
SC0422		Taşıyıcı ve Panel iç fitili Mullion-transom or Panel gasket inside	46 gr/m	15 kg	326 m	

ÇT68
ÇELİK TAKVİYELİ CEPHE
STEEL REINFORCED FACADE

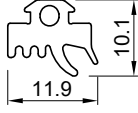
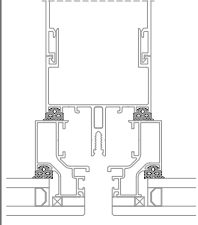
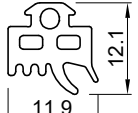
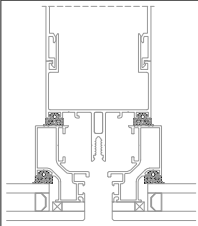
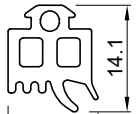
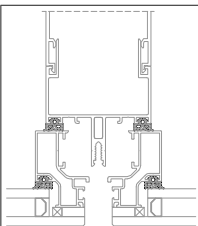
Fitil listesi
Gasket list

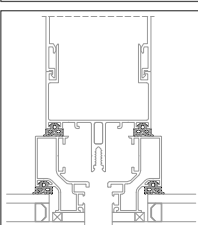
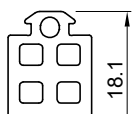
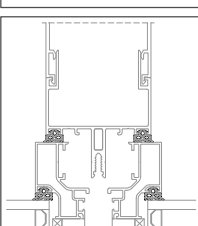
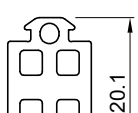
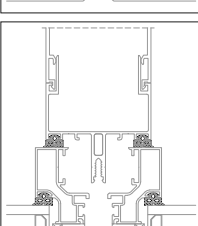
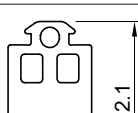
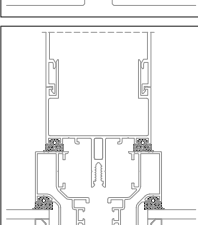
kod code	şekil drawing	tanım description	teorik ağırlık theoretical weight gr / m	paket ağırlığı package weight kg / package	paket metrajı in one package metre / package	kullanım yeri aplication
SC0407		Taşıyıcı ve Panel iç fitili Mullion-transom or Panel gasket inside	73 gr/m	15 kg	205 m	
SC0408		Taşıyıcı ve Panel iç fitili Mullion-transom or Panel gasket inside	88 gr/m	15 kg	170 m	
SC0409		Taşıyıcı ve Panel iç fitili Mullion-transom or Panel gasket inside	101 gr/m	15 kg	148 m	
SC0410		Taşıyıcı ve Panel iç fitili Mullion-transom or Panel gasket inside	113 gr/m	15 kg	133 m	
SC0411		Taşıyıcı ve Panel iç fitili Mullion-transom or Panel gasket inside	144 gr/m	15 kg	104 m	
SC0420		Taşıyıcı ve Panel iç fitili Mullion-transom or Panel gasket inside	167 gr/m	15 kg	90 m	
SC0421		Taşıyıcı ve Panel iç fitili Mullion-transom or Panel gasket inside	189 gr/m	15 kg	79 m	

Profil değerleri teoriktir. Ağırlık olarak testimde yapılan tartım geçerlidir.
Profil imalatları TS EN 12020-2 ve TS EN 755-9 toleransı,
Moment değerleri EN 14024'e göre hesaplanmıştır.

Profile values are theoretical pre-shipment weight will be valid.
The tolerances of Profile manufacturing are calculated according to EN 12020-2
and TS EN 755-9; moment values are calculated according to EN 14024.

ÇT68
ÇELİK TAKVİYELİ CEPHE
STEEL REINFORCED FACADE

Fitil listesi
Gasket list

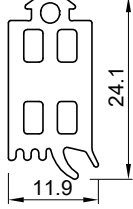
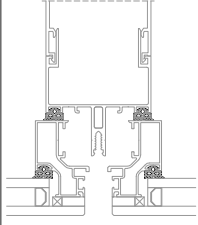
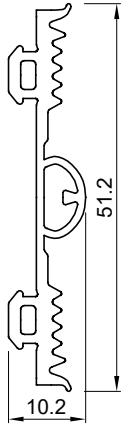
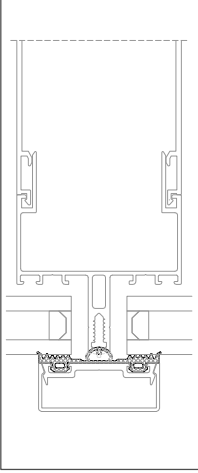
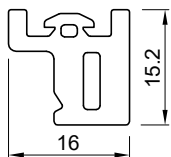
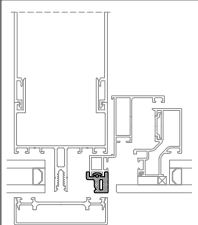
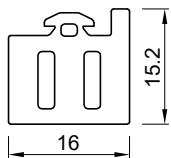
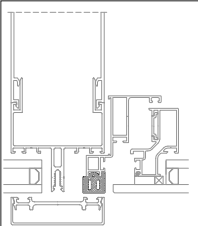
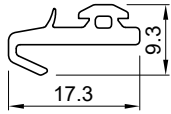
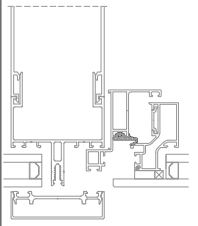
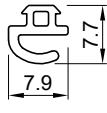
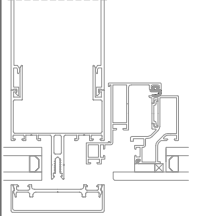
kod code	şekil drawing	tanım description	teorik ağırlık theoretical weight gr / m	paket ağırlığı package weight kg / package	paket metraji in one package metre / package	kullanım yeri aplication
SC0425		Taşıyıcı ve Panel iç fitili Mullion-transom or Panel gasket inside	217,6 gr/m	15 kg	69 m	
KC0401		Baskı profil fitili Glazing gasket	198 gr/m	15 kg	76 m	
KC0405		Kasa dış fitili Frame gasket	198 gr/m	15 kg	76 m	
KC0406		Kasa dış fitili Frame gasket	256 gr/m	15 kg	58,5 m	
KC0407		Kasa bini fitili Frame gasket	72,5 gr/m	15 kg	207 m	
KC0410		Kasa çarpma fitili Frame gasket	34 gr/m	15 kg	441 m	

Profil değerleri teoriktir. Ağırlık olarak teslimde yapılan tartım geçerlidir.
Profil imalatları TS EN 12020-2 ve TS EN 755-9 toleransı,
Moment değerleri EN 14024'e göre hesaplanmıştır.

Profile values are theoretical pre-shipment weight will be valid.
The tolerances of Profile manufacturing are calculated according to EN 12020-2
and TS EN 755-9; moment values are calculated according to EN 14024.

ÇT68
ÇELİK TAKVİYELİ CEPHE
STEEL REINFORCED FACADE

Fitil listesi
Gasket list

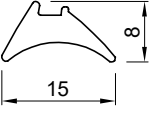
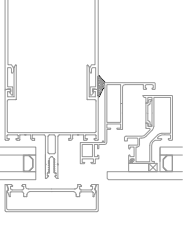
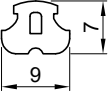
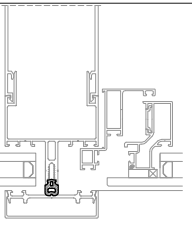
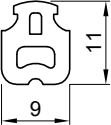
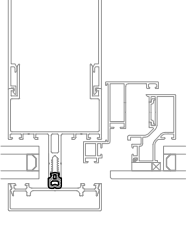
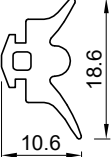
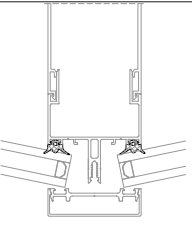
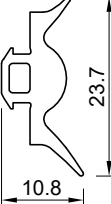
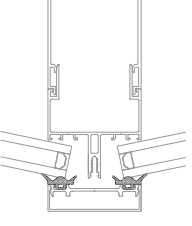
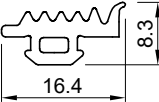
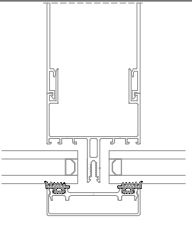
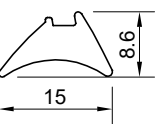
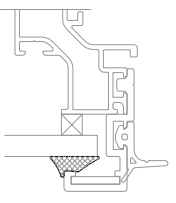
kod code	şekil drawing	tanım description	teorik ağırlık theoretical weight gr / m	paket ağırlığı package weight kg / package	paket metrajı in one package metre / package	kullanım yeri aplication
KC0411		Kasa çarpma fitili Frame gasket	64 gr/m	15 kg	234 m	
KC0412		Taşıyıcı ön fitili Mullion-transom gasket front	24,6 gr/m	15 kg	275 m	
KC0413		Taşıyıcı ön fitili Mullion-transom gasket front	80 gr/m	15 kg	187,5 m	
KC0415		Açılı köşe fitili Mullion-transom gasket inside	80 gr/m	15 kg	187 m	
KC0417		Açılı köşe fitili Mullion-transom gasket inside	96 gr/m	15 kg	156 m	
KC0419		Baskı profil fitili Glazing gasket	73 gr/m	15 kg	205 m	
SC0417		Kalın kama fitili Frame gasket inside	96 gr/m	15 kg	156 m	

ÇT68
ÇELİK TAKVİYELİ CEPHE
STEEL REINFORCED FACADE

Fitil listesi
Gasket list

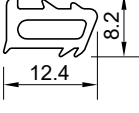
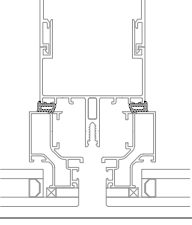
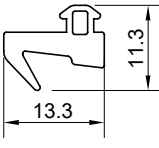
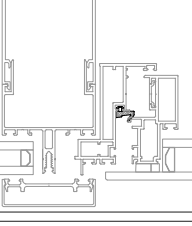
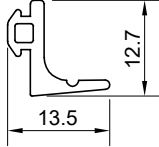
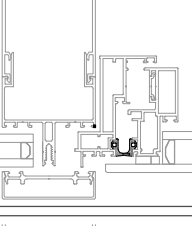
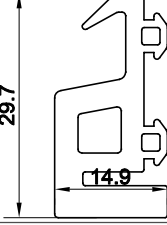
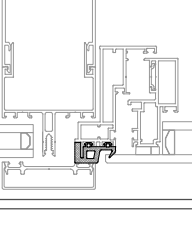
kod code	şekil drawing	tanım description	teorik ağırlık teoretical weight gr / m	paket ağırlığı package weight kg / package	paket metraji in one package metre / package	kullanım yeri aplication
SC0423		Taşıyıcı ve Panel iç fitili Mullion-transom or Panel gasket inside	54 gr/m	15 kg	278 m	
EC0403		Kasa bini fitili Frame gasket	80 gr/m	15 kg	187.5 m	
EC0404		Panel dış fitili Frame gasket	59 gr/m	15 kg	254 m	
KC0402		Kasa dış fitili Frame gasket	302.5 gr/m	15 kg	50 m	

ÇT68
ÇELİK TAKVİYELİ CEPHE
STEEL REINFORCED FACADE

Pvc ızalasyon listesi
Pvc ızalator list

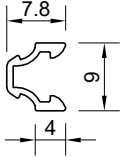
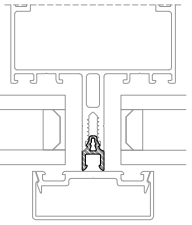
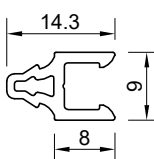
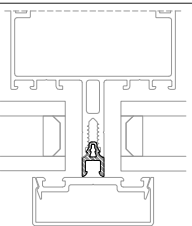
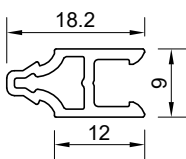
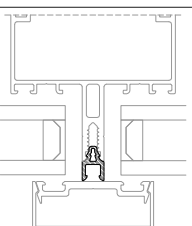
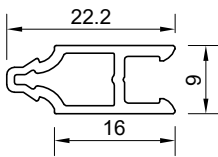
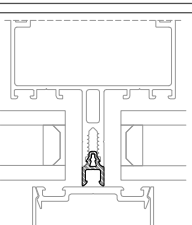
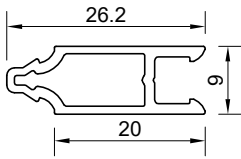
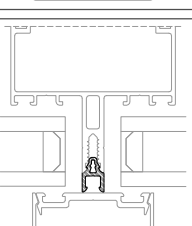
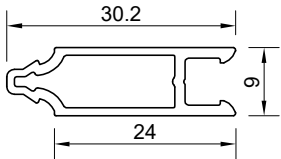
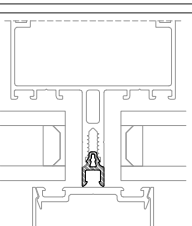
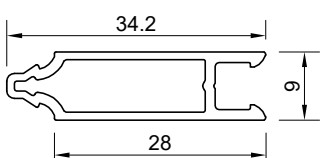
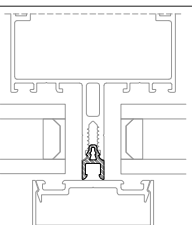
kod code	şekil drawing	tanım description	metraji metre / package	kullanım yeri aplication
F0500		Taşıyıcı ön ızalasyon (pvc) Mullion or transom front ızalator (pvc)	6 m	
F0501		Taşıyıcı ön ızalasyon (pvc) Mullion or transom front ızalator (pvc)	6 m	
F0502		Taşıyıcı ön ızalasyon (pvc) Mullion or transom front ızalator (pvc)	6 m	
F0503		Taşıyıcı ön ızalasyon (pvc) Mullion or transom front ızalator (pvc)	6 m	
F0504		Taşıyıcı ön ızalasyon (pvc) Mullion or transom front ızalator (pvc)	6 m	
F0505		Taşıyıcı ön ızalasyon (pvc) Mullion or transom front ızalator (pvc)	6 m	
F0506		Taşıyıcı ön ızalasyon (pvc) Mullion or transom front ızalator (pvc)	6 m	

ÇT68
ÇELİK TAKVİYELİ CEPHE
STEEL REINFORCED FACADE

Pvc ızalasyon listesi
Pvc ızalator list

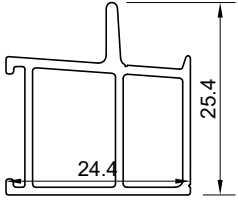
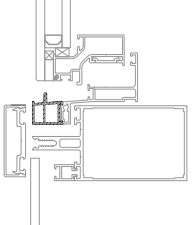
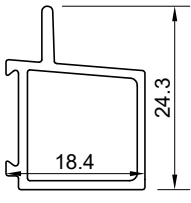
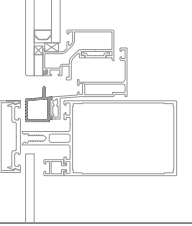
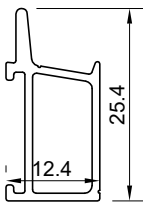
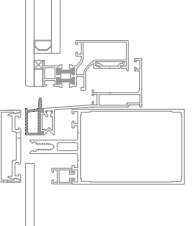
kod code	şekil drawing	tanım description	metraji metre / package	kullanım yeri aplication
F0520		Kasa profili ızalasyon (pvc) Frame profile ızalator (pvc)	6 m	
F0521		Kasa profili ızalasyon (pvc) Frame profile ızalator (pvc)	6 m	
F0522		Kasa profili ızalasyon (pvc) Frame profile ızalator (pvc)	6 m	

ÇT68

ÇELİK TAKVİYELİ CEPHE

STEEL REINFORCED FACADE

İMALAT ŞEMASI
PRODUCTION PLAN

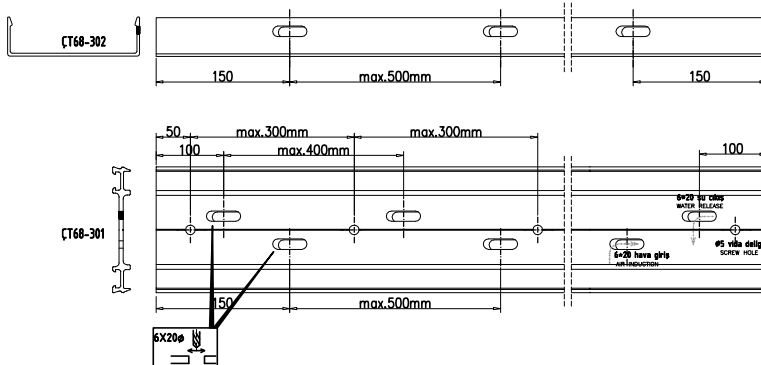
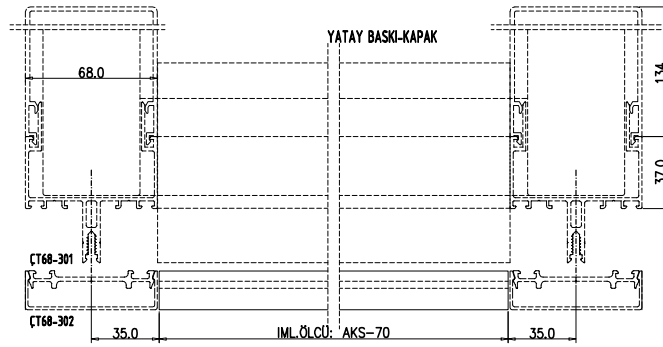
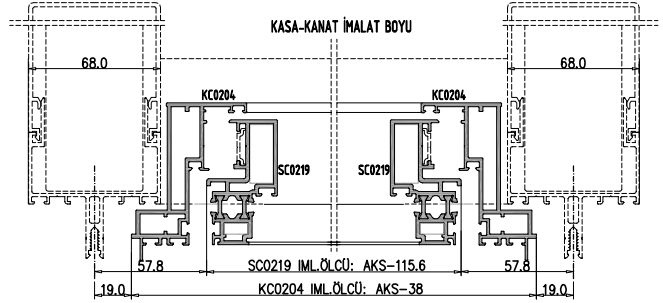
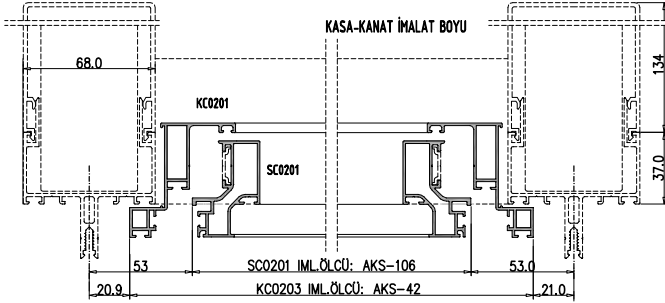
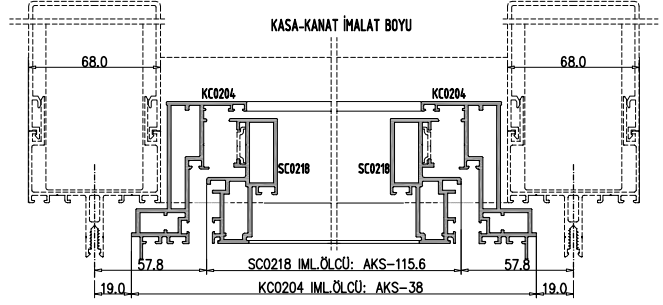
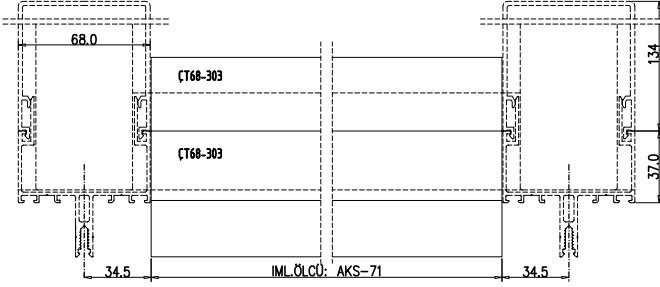

ÇT68

ÇELİK TAKVİYELİ CEPHE

STEEL REINFORCED FACADE

AKSESUARLAR
ACCESSOIRES

YÜKSEKLİĞE VE AĞIRLIĞA GÖRE MAXIMUM KANAT GENİSLİKLERİ
WIDTH ACCORDING TO THE WEIGHT AND THE HEIGHT

max. en boy ölçüsü

Tablodaki değerler ithal için geçerlidir.
All values are just for import

(20kg-50kg)

h/kg	20 kg	25 kg	30 kg	35 kg	40 kg	45 kg	50 kg	en mm
450	1500	1500	1500	1500	1500	1500	1500	weight mm
500	1500	1500	1500	1500	1500	1500	1500	
550	1500	1500	1500	1500	1500	1500	1500	
600	1500	1500	1500	1500	1500	1500	1400	
650	1500	1500	1500	1500	1500	1400	1292	
700	1500	1500	1500	1500	1400	1300	1200	
750	1500	1500	1500	1400	1307	1213	1120	
en mm								

SC0319 (ithal)
(import)
SC0319-a (yerli)
(native)
TYPE P - 10"
w = 23 mm
l = 261.5 mm
degree of opening 35°

(30kg-60kg)

h/kg	30 kg	35 kg	40 kg	45 kg	50 kg	55 kg	60 kg	en mm
500	1500	1500	1500	1500	1500	1500	1500	weight mm
550	1500	1500	1500	1500	1500	1500	1500	
600	1500	1500	1500	1500	1500	1500	1500	
650	1500	1500	1500	1500	1500	1500	1477	
700	1500	1500	1500	1500	1500	1472	1371	
750	1500	1500	1500	1500	1467	1373	1280	
800	1500	1500	1500	1463	1375	1288	1200	
850	1500	1500	1459	1400	1294	1212	1129	
en mm								

SC0320 (ithal)
(import)
SC0320-a (yerli)
(native)
TYPE P - 12"
w = 23 mm
l = 317.5 mm
degree of opening 35°

(35kg-69,5kg)

h/kg	35 kg	40 kg	45 kg	50 kg	55 kg	60 kg	65 kg	69 kg	en mm	
550	1625	1625	1625	1625	1625	1625	1625	1625	weight mm	
600	1625	1625	1625	1625	1625	1625	1625	1625		
650	1625	1625	1625	1625	1625	1625	1625	1625		
700	1625	1625	1625	1625	1625	1625	1625	1625		
750	1625	1625	1625	1625	1625	1625	1625	1625		
800	1625	1625	1625	1625	1625	1625	1625	1625		
850	1625	1625	1625	1625	1625	1604	1529			
900	1625	1625	1625	1625	1604	1514	1444			
950	1625	1625	1625	1625	1582	1514	1435	1368		
1000	1625	1625	1625	1573	1503	1625	1363	1300		
1050	1625	1625	1565	1498	1432	1625	1298	1238		
en mm										

SC0321 (ithal)
(import)
SC0321-a (yerli)
(native)
TYPE P - 14"
w = 23 mm
l = 353.5 mm
degree of opening 35°

(45kg-88,5kg)

h/kg	45 kg	50 kg	55 kg	60 kg	65 kg	70 kg	75 kg	80 kg	85 kg	88,5kg	en mm	
600	1750	1750	1750	1750	1750	1750	1750	1750	1750	1750	weight mm	
650	1750	1750	1750	1750	1750	1750	1750	1750	1750	1750		
700	1750	1750	1750	1750	1750	1750	1750	1750	1750	1750		
750	1750	1750	1750	1750	1750	1750	1750	1750	1750	1750		
800	1750	1750	1750	1750	1750	1750	1750	1750	1750	1750		
850	1750	1750	1750	1750	1750	1750	1750	1750	1750	1750		
900	1750	1750	1750	1750	1750	1750	1750	1750	1750	1750		
950	1750	1750	1750	1750	1750	1750	1750	1750	1750	1750		
1000	1750	1750	1750	1750	1750	1750	1750	1750	1739	1680		
1050	1750	1750	1750	1750	1750	1750	1750	1738	1657	1600		
1100	1750	1750	1750	1750	1750	1750	1736	1659	1581	1527		
1150	1750	1750	1750	1750	1750	1734	1660	1586	1513	1461		
1200	1750	1750	1750	1750	1733	1662	1591	1520	1450	1400		
1250	1750	1750	1750	1731	1663	1595	1528	1460	1392	1344		
1300	1750	1750	1730	1665	1560	1534	1470	1403	1338	1292		
en mm												

SC0322 (ithal)
(import)
SC0322-a (yerli)
(native)
TYPE P - 16"
w = 23 mm
l = 414.5 mm
degree of opening 30°

(55kg-102kg)

h/kg	55 kg	60 kg	65 kg	70 kg	75 kg	80 kg	85 kg	90 kg	95 kg	102 kg	en mm	
650	1750	1750	1750	1750	1750	1750	1750	1750	1750	1750	weight mm	
750	1750	1750	1750	1750	1750	1750	1750	1750	1750	1750		
850	1750	1750	1750	1750	1750	1750	1750	1750	1750	1750		
950	1750	1750	1750	1750	1750	1750	1750	1750	1750	1750		
850	1750	1750	1750	1750	1750	1750	1750	1750	1750	1750		
1050	1750	1750	1750	1750	1750	1750	1750	1750	1750	1704		
1150	1750	1750	1750	1750	1750	1750	1750	1731	1663	1568		
1250	1750	1750	1750	1750	1750	1729	1666	1603	1540	1452		
1350	1750	1750	1750	1750	1728	1667	1606	1546	1485	1400		
1450	1750	1750	1750	1727	1668	1610	1551	1492	1434	1352		
1500	1750	1750	1750	1669	1613	1556	1499	1443	1386	1307		
en mm												

SC0323 (ithal)
(import)
SC0323-a (yerli)
(native)
TYPE P - 18"
w = 23 mm
l = 458.5 mm
degree of opening 30°

(80kg-135kg)

h/kg	80 kg	90 kg	100 kg	110 kg	120 kg	130 kg	135 kg	en mm	
700	1875	1875	1875	1875	1875	1875	1875	weight mm	
800	1875	1875	1875	1875	1875	1875	1875		
900	1875	1875	1875	1875	1875	1875	1875		
1000	1875	1875	1875	1875	1875	1875	1875		
1100	1875	1875	1875	1875	1875	1875	1875		
1200	1875	1875	1875	1875	1875	1875	1875		
1300	1875	1875	1875	1875	1875	1875	1846		
1400	1875	1875	1875	1875	1875	1789	1714		
1500	1875	1875	1875	1875	1810	1566	1600		
1600	1875	1875	1875	1829	1697	1875	1500		
1700	1875	1875	1845	1721	1597	1474	1412		
en mm									

SC0324 (ithal)
(import)
SC0324-a (yerli)
(native)
TYPE P - 20"
w = 23 mm
l = 511.5 mm
degree of opening 25°

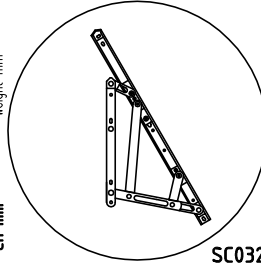

(90kg-137kg)

h/kg	90 kg	100 kg	110 kg	120 kg	130 kg	137 kg	en mm
750	1875	1875	1875	1875	1875	1875	weight mm
900	1875	1875	1875	1875	1875	1875	
1000	1875	1875	1875	1875	1875	1875	
1100	1875	1875	1875	1875	1875	1875	
1200	1875	1875	1875	1875	1875	1875	
1300	1875	1875	1875	1875	1875	1875	
1400	1875	1875	1875	1875	1875	1821	
1500	1875	1875	1875	1875	1798	1700	
1600	1875	1875	1875	1875	1686	1594	
1700	1875	1875	1834	1710	1587	1500	
1800	1875	1875	1734	1610	1498	1417	
en mm							

SC0325 (ithal)
(import)
SC0325-a (yerli)
(native)
TYPE P - 22"
w = 23 mm
l = 556.5 mm
degree of opening 25°

(90kg-137kg)

h/kg	90 kg	100 kg	110 kg	120 kg	130 kg	139 kg	en mm	
800	1875	1875	1875	1875	1875	1875	weight mm	
950	1875	1875	1875	1875	1875	1875		
1100	1875	1875	1875	1875	1875	1875		
1200	1875	1875	1875	1875	1875	1875		
1300	1875	1875	1875	1875	1875	1875		
1400	1875	1875	1875	1875	1875	1875		
1500	1875	1875	1875	1875	1875	1800		
1600	1875	1875	1875	1875	1806	1688		
1700	1875	1875	1875	1823	1700	1588		
1800	1875	1875	1839	1722	1605	1500		
1900	1875	1875	1742	1631	1521	1421		
en mm								

SC0326 (ithal)
(import)
SC0326-a (yerli)
(native)
TYPE P - 24"
w = 23 mm
l = 602.5 mm
degree of opening 25°

(90kg-137kg)

h/kg	105 kg	115 kg	125 kg	135 kg	145 kg	155 kg	en mm	
900	1875	1875	1875	1875	1875	1875	weight mm	
1100	1875	1875	1875	1875	1875	1875		
1300	1875	1875	1875	1875	1875	1875		
1500	1875	1875	1875	1875	1875	1875		
1600	1875	1875	1875	1875	1875	1875		
1700	1875	1875	1875	1875	1875	1765		
1800	1875	1875	1875	1875	1816	1667		
1900	1875	1875	1875	1863	1721	1579		
2000	1875	1875	1875	1770	1635	1500		
2100	1875	1875	1814	1685	1557	1429		
en mm								

SC0327 (ithal)
(import)
SC0327-a (yerli)
(native)
TYPE P -

ÇT68
ÇELİK TAKVİYELİ CEPHE
STEEL REINFORCED FAÇADE

AKSESUARLAR
ACCESSOIRES

DALDIRMA GALVENİZLİ SABİT U ANKRAJ (YATAY BAKLALI)
DIP GALVANIZED FIX "U" ANCHOR (HORIZONTAL)

- SC0338-2 (yerli) (native) L= 80 mm
SC0339-2 (yerli) (native) L= 100 mm
SC0340-2 (yerli) (native) L= 120 mm
SC0341-2 (yerli) (native) L= 150 mm
SC0342-2 (yerli) (native) L= 200 mm

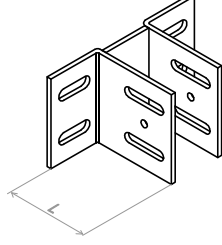

DALDIRMA GALVENİZLİ SABİT U ANKRAJ (DÜŞEY BAKLALI)
DIP GALVANIZED FIX "U" ANCHOR (VERTICAL)

- SC0338-1 (yerli) (native) L= 80 mm
SC0339-1 (yerli) (native) L= 100 mm
SC0340-1 (yerli) (native) L= 120 mm
SC0341-1 (yerli) (native) L= 150 mm
SC0342-1 (yerli) (native) L= 200 mm

